

# Monitoring, analysis and diagnosis

## OnCare.Health Hydro







**The OnCare.Health Hydro monitoring, analysis and diagnosis system combines our engineering and manufacturing expertise with your operational experience and knowledge to design a powerful predictive maintenance tool tailored to your individual hydropower plant.**





1 Picote, Portugal

2 Herdecke, Germany

A power plant's one and only objective is to fully meet the electricity demands for a maximum of time at the lowest possible cost. Therefore, efficiency, reliability and availability are crucial, and it is of highest importance that the machines are kept operating under optimum conditions. A key factor to meet these demands is to be able to support early fault detection and preventive maintenance techniques.

This is the focus of OnCare.Health Hydro, which is designed to obtain early detection of incipient damages, reduction of inspection and repair work, and clear planning options for timely inspections.

Among series of monitoring and evaluation methods for probable root causes in machine behavior, vibration diagnosis and air gap analysis are examples of well-known and acknowledged machine monitoring methods in the hydropower industry.

Both have gained importance and have become part of condition-based maintenance for hydroelectric equipment, and match today's needs with respect to measuring technology, data processing and evaluation procedures.

# Condition monitoring system OnCare.Health Hydro

OnCare.Health Hydro is an online monitoring, analysis and diagnosis system developed by Voith Digital Ventures, combining the know-how and experience of international hydropower operation from Voith, which has deep knowledge and expertise in hydropower layout and design.

To meet various demands for different types, sizes and operation modes of hydropower machines, we offer:

- Highly scalable systems
- Custom-tailored solutions regarding protection, monitoring, analysis and diagnosis
- Predefined standard configurations for sensors to assure reliable and safe measurement

Our modules are designed as an integral part of our control system family, making it more beneficial, because no interfaces have to be clarified, and information already available in the control system does not have to be acquired twice.

To maximize the flexibility, the system is designed in three hierarchical levels:

- Monitoring
- Analysis
- Diagnosis

We also offer flexible solutions for hardware configuration and integration to be implemented into your existing plant control system.

## Overall benefits OnCare.Health Hydro

- + Optimized total cost of ownership
- + Reduced costs
- + Increased availability
- + Voith know-how implementation

## Hardware configuration

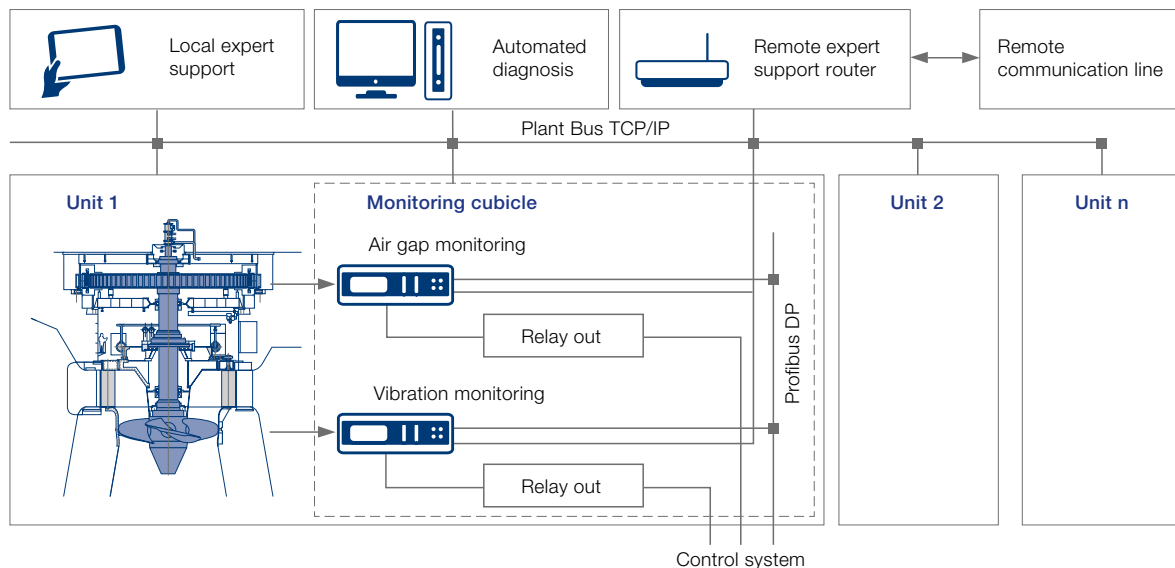

100 % time-synchronous 50 kHz sampling rate per channel and high 24 bit resolution.

All types of vibration sensors can be connected ( $\mu\text{m}$ ,  $\text{mm/s}$ ,  $\text{m/s}^2$ ).

Internal power supply for IEPE sensors available.

Voith scope of turbine and generator supply

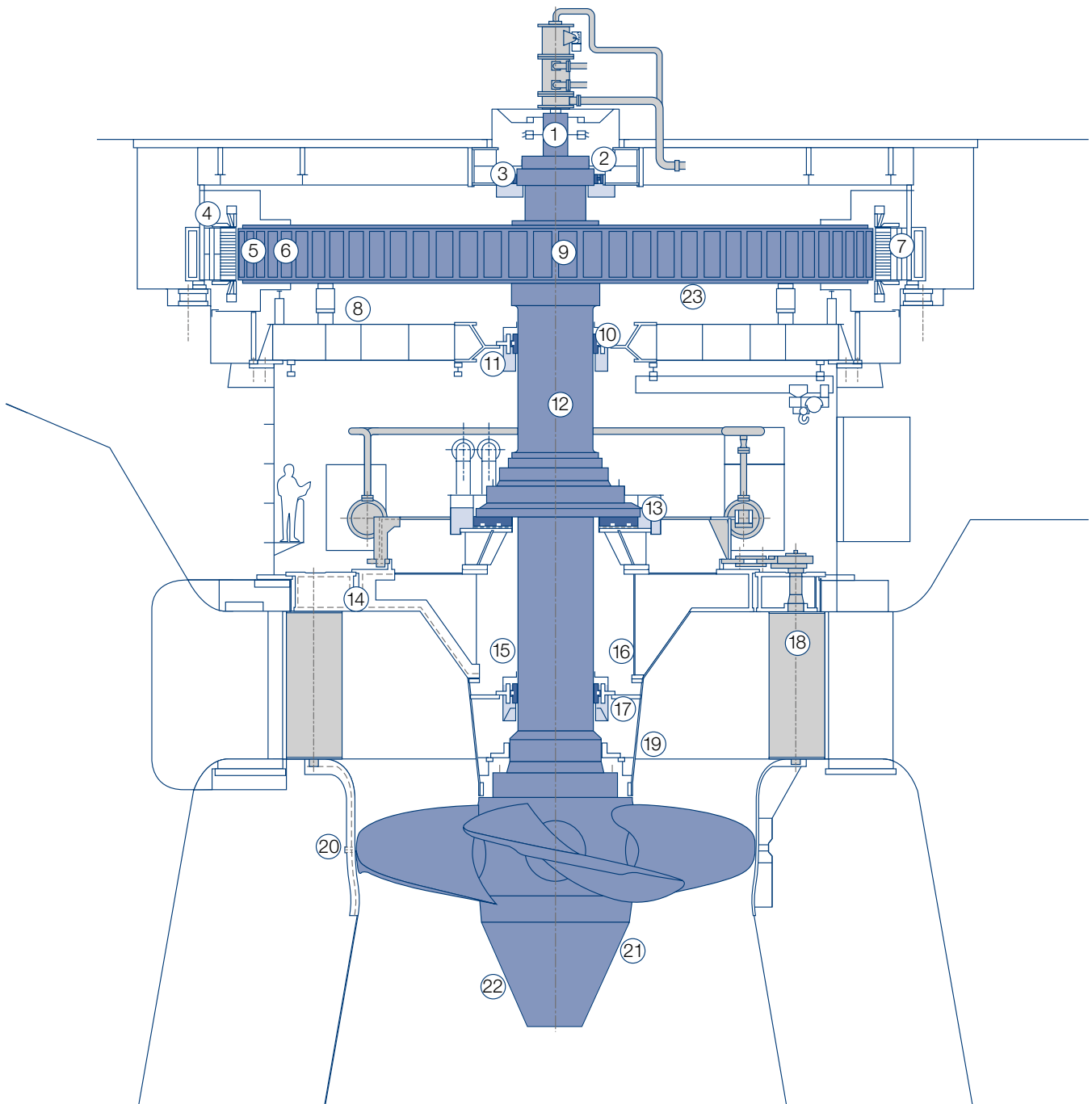

- |                                    |   |                               |
|------------------------------------|---|-------------------------------|
| 1 Keyphasor                        | 9 Partial discharge   | 16 Shaft relative vibration   |
| 2 Absolute bearing vibration       | 10 Absolute bearing vibration                                 | 17 Absolute bearing vibration |
| 3 Shaft relative vibration         | 11 Shaft relative vibration                                   | 18 Wicket gate vibration      |
| 4 Stator end winding vibration     | 12 Shaft current monitoring                                   | 19 Labyrinth gap (Francis)    |
| 5 Air gap                          | 13 Axial thrust vibration/<br>movement and oil film thickness | 20 Runner gap (Kaplan/Bulb)   |
| 6 Magnetic flux                    | 14 Turbine headcover vibration                                | 21 Cavitation monitoring      |
| 7 Stator core vibration            | 15 Turbine temperature monitoring                             | 22 Pressure                   |
| 8 Generator temperature monitoring |   | 23 Ozone monitoring           |

# Monitoring interface

Reliable measurement and signal processing plus a well-engineered unit protection concept are considered to be of paramount importance for plant safety.

## Monitoring

The highly sensitive measuring systems that are adapted to the requirements of hydropower machines ensure effective condition-based monitoring and maintenance, and thus increase the life cycle of rotating machines as well as increasing plant availability and reliability.

To provide plant safety, the primary tasks of monitoring are to:

- Identify the plant's individual optimum condition
- Recognize imminent damage early on
- Optimize modes of operation
- Allow for scheduled maintenance

For complex excitation mechanisms with high dependency on specific operation conditions of the unit, special monitoring techniques are applied. The HyCon MD monitoring module evaluates all measurements and characteristic values as a function of operation mode and operation point.

## Additional features

Our data acquisition devices include logical functions based on parameters that generate trip signals to be transferred to the mechanical protection of the unit. This requires simple and reliable solutions that, at the same time, need to be flexible to meet various machine characteristics that are highly dependent on operating conditions.

## Unit monitoring

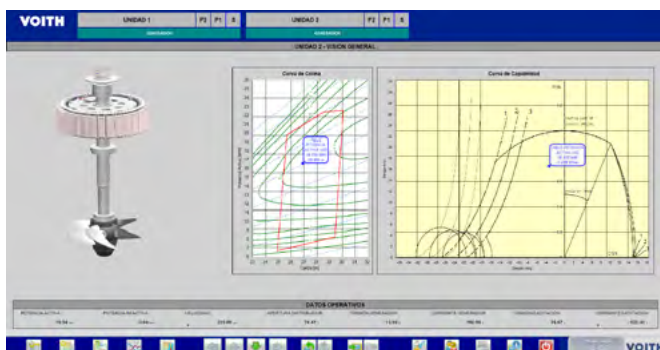

## User friendly interface

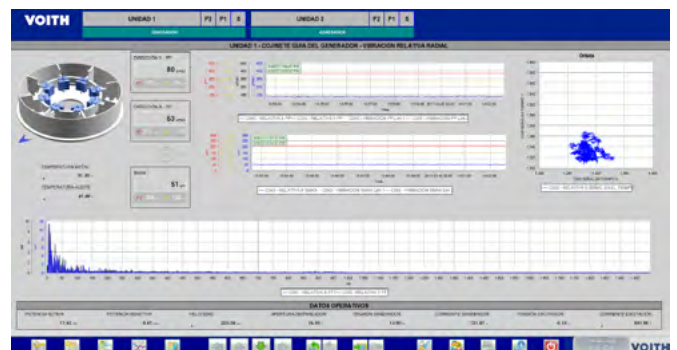



# Intelligent measurement and analysis for additional benefits

In order to add on benefits for plant operators, our systems are designed to efficiently support predictive maintenance strategies.

## More than monitoring

Most monitoring systems only measure values and create alarms based on limit values. In order to extend the benefit for the plant operator, the system must be able to efficiently support preventive maintenance strategies.

To fulfill this demand, the following prerequisites must be met:

- Highly sensitive measurement technology with adapted analysis techniques
- Diagnostic intelligence for proper selection of specific parameters and comparison of the measured values with the expected behavior, depending on specific plant conditions and machine operation modes
- Tailor-made systems to meet specific conditions such as very low speed or various operating modes with highly volatile excitation requirements
- Precise machine monitoring through intelligent measuring and analysis systems covering analytic evaluation of pre-processed values from the measurement device, for example, frequency analysis providing frequency-selective observation results, and the calculation of further hydro-specific characteristic values.

Our modules are specifically designed to meet these advanced requirements.

## Statistic module

To increase the information content of, for example, vibration signals, as well as to represent the great variety of vibration-related factors, our statistic module is flexible to provide measurement values from any desired process variable. Different measurement planes, signals and key parameters can thus be compared.

## Shaft vibration

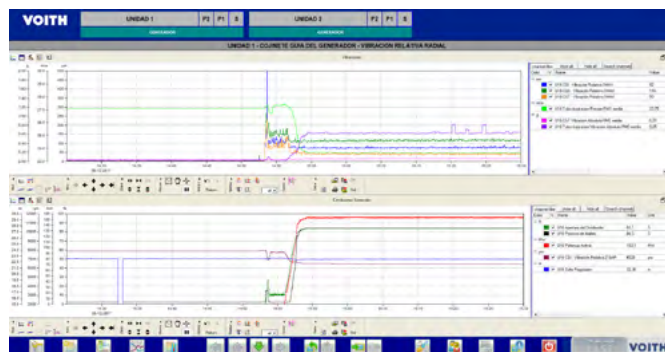

## Shaft signal analysis

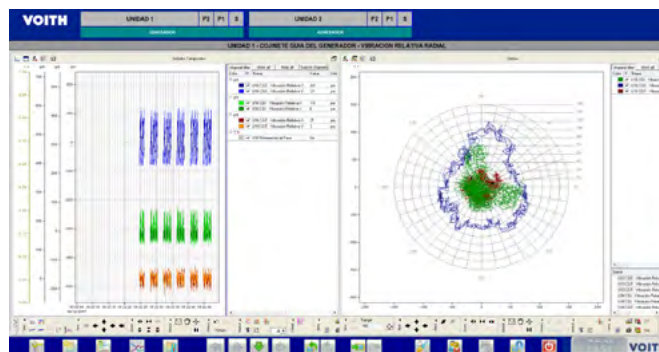

# Value added for the operator

## Expert diagnosis

OnCare.Health Hydro, with its flexibility and adaptive modular configuration, provides a powerful tool for you to do reliable diagnostics for safe operation all the time.

Many monitoring systems are available that are able to measure and present results using standard evaluation methods. In contrast, Voith, as an equipment manufacturer, understands the process and knows how to interpret these measurements. This knowledge is integrated in the OnCare.HealthHydro system – a clear added value for the plant operator.

In order to automate diagnostic tasks, a knowledge database processes the results of the analysis.

### Diagnosis user interface

Clear and basic information on the machine's condition is presented to the operator through user-friendly interfaces. Whenever information about a problem becomes evident, the results are passed to the user as a list of clearly identified failure causes including error probabilities.

### Unit monitoring

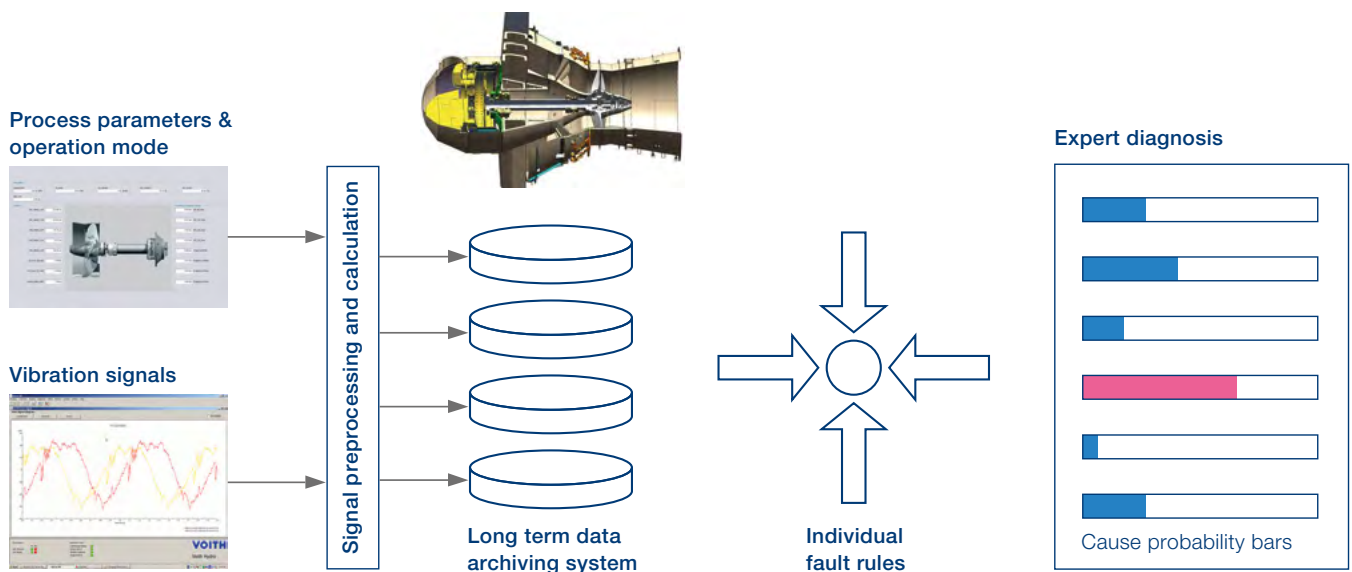





OnCare.Health Hydro

### OnCare.Health Hydro – the benefits of an online monitoring system

- + Machine behavior monitoring
- + Assess the condition of a hydropower unit to enable condition-based maintenance
- + Scalable monitoring function
- + Commissioning support for balancing
- + Integrated analysis functions
- + Standard configured electrical panel (micro, compact, standard, mega)
- + Flexible connection to foreign systems
- + Upgrade for automated diagnosis without system configuration change
- + Remote connection offers expert know-how on demand
- + Back-up support for field service with full access to on-site data
- + Prepared for troubleshooting by Voith experts
- + If required, HTML5 visualization, and therefore platform-independent measurement data on any user device (desktops, notebooks, tablets or smartphones)
- + Mobile with high-resolution data acquisition for vibrations and process values measuring
- + Cloud-ready monitoring system with possibility to use machine learning algorithms

### Online visualization and analysis

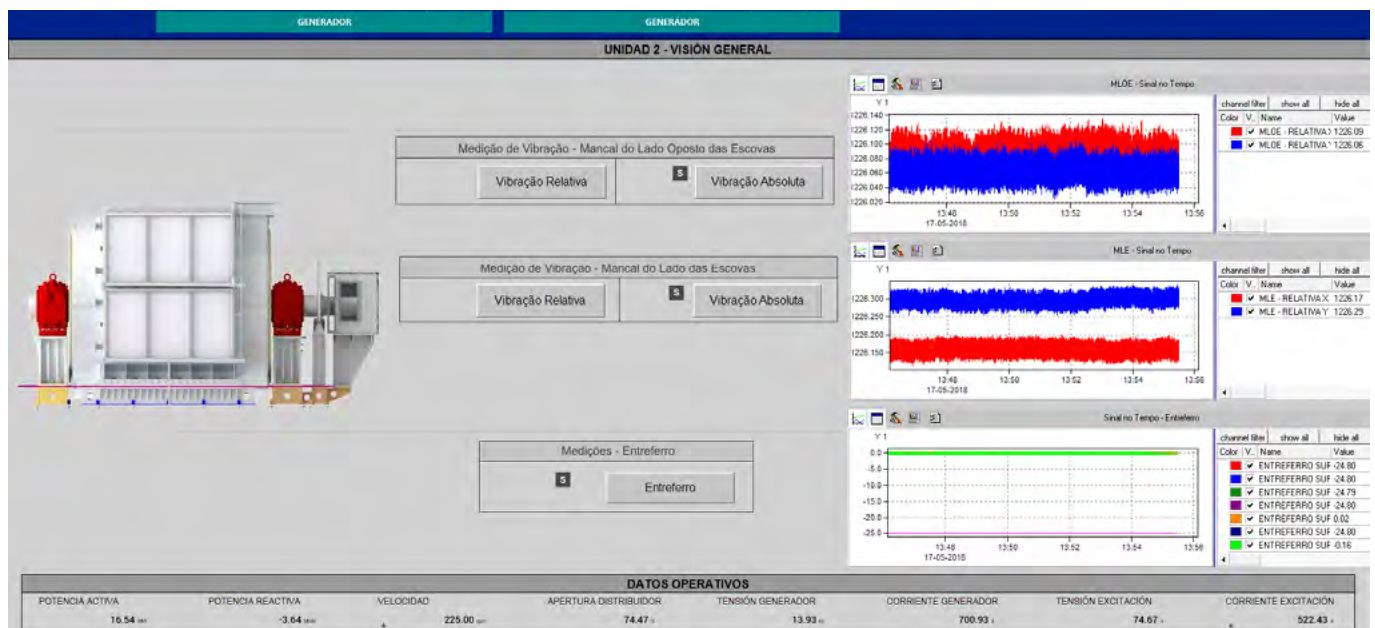

# Helping you to recognize, understand & optimize OnCare.Health Hydro offerings

## Voith also offers safe remote access from a central server to your OnCare.Health Hydro installation onsite

With this safe access possibility (only registered Voith specialists will have access to your Condition Monitoring System), we can provide additional services and guarantee even faster and better customer service.

This will help you to enhance the profitability of your plant through:

- Remote support and quick analysis in case of unforeseen unit standstills without Voith specialists going to site
- Cyclic assessments
- Commissioning, troubleshooting and analysis can be centrally supported by specialists
- Remaining work via remote access (parameter settings and configuration)

Voith is also offering a wide range of service contracts that will help you to optimize the plant conditions.

There are several options for these service contracts, such as:

- Evaluation of the machine condition
- Analysis of anomalies
- Recommendations for the correction of defects or advanced measurements to detect them
- Remote troubleshooting and system update
- Check of monitoring and data archiving system
- Alert and trip optimization
- Predefined rates for additional services (e.g., on site)

OnCare.Health Hydro report from OnPerformance.Lab provides decisive information to derive smarter recommendations and decisions.

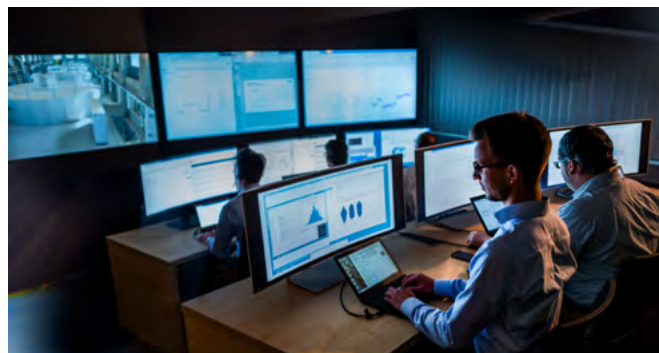

## Helping you to recognize, understand & optimize – OnCare.Health Hydro offerings



### Acquisition and protection

OnCare.Health Hydro has a very powerful device for data acquisition and characteristic values calculation. Protection interface and short recording functions are available.



### User interface and data analysis

Voith offers a supervision system with a clear and friendly interface pertaining to the actual healthy state, as well as detailed and complex data analysis.



### Report

Voith provides decisive information to derive smarter recommendations and decisions. Plant operators benefit from actionable information.



- 1 Baguari, Brazil
- 2 Omkareshwar, India

## References in recent years

- 2013** Frades, Portugal  
2 x 383 MW (Francis units)
- 2013** Yacyreta, Argentina  
20 x 145 MW (Kaplan units)
- 2014** Sainj, India  
2 x 50 (Pelton units)
- 2014** Beyhan, Turkey  
3 x 200 MW (Francis units)
- 2015** Cambambe II, Angola  
4 x 179 MW (Francis units)
- 2015** Teles Pires, Brazil  
5 x 370 MW (Francis units)
- 2016** Belo Monte, Brazil  
18 x 671 MW (Francis units)
- 2016** Polpitiya, Sri Lanka  
2 x 40 MW (Francis units)
- 2017** Lysebotn II, Norway  
2 x 185 MW (Francis units)
- 2017** Las Lajas, Chile  
2 x 135 MW (Pelton units)
- 2018** Ffestiniog, United Kingdom  
4 x 80 MW (Francis units)
- 2018** Tarbela 4, Pakistan  
4 x 352 MW (Francis units)





Voith Group  
Voith Hydro Holding GmbH & Co. KG  
Alexanderstr. 11  
89522 Heidenheim, Germany

Contact:  
Phone +49 7321 37-9990  
[digital-hydro@voith.com](mailto:digital-hydro@voith.com)  
[www.voith.com/digitalhydro](http://www.voith.com/digitalhydro)

A Voith and Siemens Company



**VOITH**  
Inspiring Technology  
for Generations