

Excellence in generator control HyCon Thyriston™ Excitation



Excitation system

The HyCon Thyricon Excitation family represents the extensive experience and knowledge of Voith as one of the major hydropower generator manufacturers. Our excitation product line offers best-in-class technology to reliably control the stator voltage and reactive power.

Voith is a global leader in hydropower plant equipment and services for both new and modernization projects. For nearly 150 years, our name has been synonymous with excellence in the hydropower industry, with almost 40 000 generators and turbines installed worldwide.

Throughout our history, we have continuously set new records in performance and size of hydropower machines and components, as well as having a high understanding of solutions from our staff around the world. This combination has supplied best designs and solutions based on state-of-the-art engineering and manufacturing expertise.

HyCon Thyricon, the Voith excitation product line, ensures excellence in generator control. This modular system can be customized to provide an optimized solution for all ranges of synchronous generators and motors.

Many configurations are available, including redundant controllers and fully or $n + 1$ redundant thyristor bridges. All parts of the HyCon Thyricon family are factory-tested prior to shipment. The comprehensive controller software includes special features like data logging function – where all parameters are accessible through the operator panel and can be changed online without operation interruption – as well as special modules for the service and commissioning teams.

From the simplest system to the complex redundant programmable controllers and redundant rectifier bridges



HyCon Thyricon family

An excitation system comprises all the devices responsible for delivering the field current to a synchronous generator along with the equipment responsible for regulating the stator voltage, including the limiting and protecting functions. Voith provides excitation systems for a wide range of hydro generators. All families use standard industrial off-the-shelf hardware components with worldwide support.

Excitation systems for a wide range of hydropower generators.

The HyCon Thyricon Family consists of the following members

Family	Thyricon 300	Thyricon 400	Thyricon 500	Thyricon 600
Module(s)	1	1 – 3	4 – 5	5 – 7
Type of rectifier	IGBT	Thyristor	Thyristor	Thyristor
Rectifier redundancy	None or (1+1)	None	(1+1)	(n+1)
Cooling type	Natural or forced	Natural or forced	Natural or forced	Forced
Cooling redundancy	Optional	Optional	Optional	Optional
Circuit breaker type	Contactors or MCCB	Air circuit breaker or DC contactor with discharge contact	Air circuit breaker or DC contactor with discharge contact	Air circuit breaker or DC contactor with discharge contact
Circuit breaker location	AC or DC side	AC or DC side	AC and/or DC sides	AC and/or DC sides
Max. continuous current [A]	Up to 150	Up to 3 000	Up to 3 000	Up to 10 000
Max. output voltage [V]	Up to 600	Up to 2 000	Up to 2 000	Up to 2 000
Controller platform	Siemens or others	Siemens or others	Siemens or others	Siemens or others
Controller redundancy	Optional	Optional	Optional	Optional

Digital voltage regulator

Control features

The voltage regulator's primary task is to keep the voltage of the generator constant. It is also required to maintain the stability of the generator in steady-state conditions, as well as during transient disturbances. The voltage regulator covers all control functions needed for excitation systems. The micro-processing capacity makes it possible to realize accurate control functions, and the digital technology provides good long-term stability.

The Thyricon Excitation system has a future-proof concept; its highly modular design allows future upgrades and integration of different hardware. The software logics are widely configurable and allow customization to different applications and customer requirements. Also, the modularity of HyCon Thyricon Excitation system can improve existing exciters, modularizing and modernizing them, adding value for customers.

HyCon Thyricon Excitation systems

Simplified diagram of a static excitation system and the generator unit

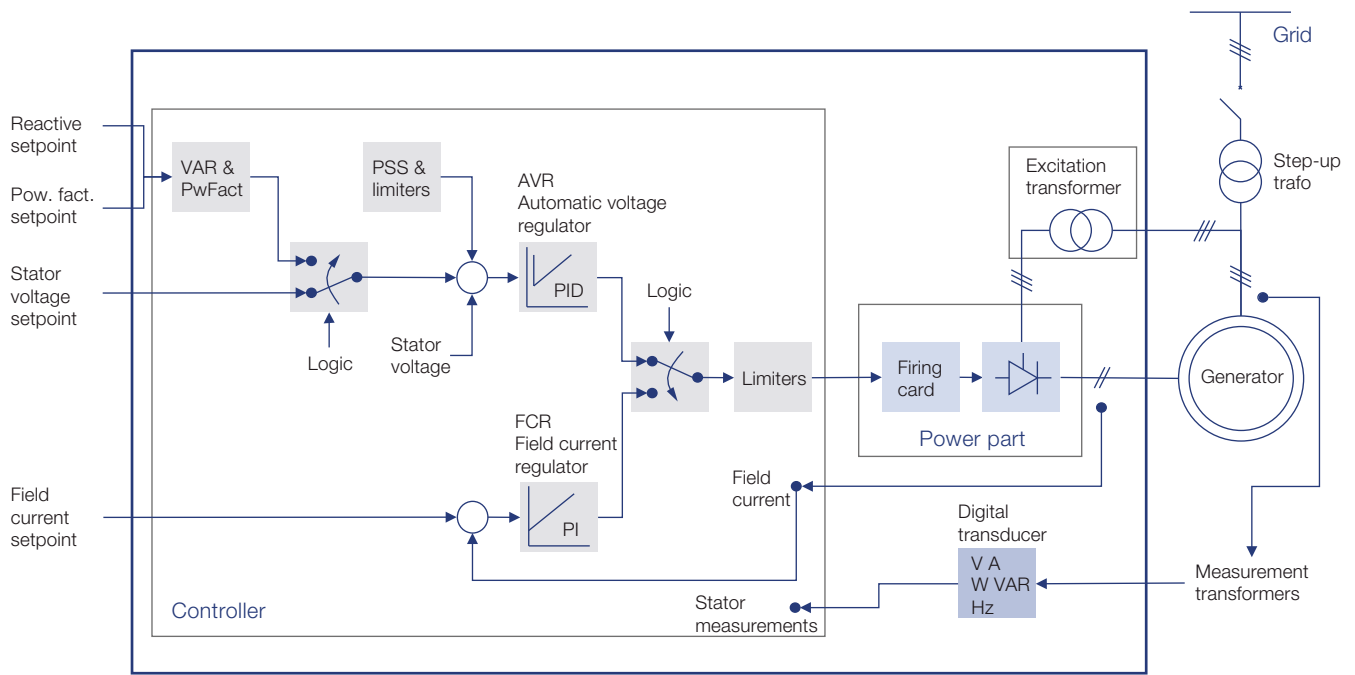

Digital measuring transducers

Measuring of stator voltage and current is done by fast A/D conversions of each phase value several times per period. True RMS value is calculated by the measuring device.

Automatic voltage regulator (AVR)

The AVR control algorithm of PID characteristic regulates the stator voltage to the desired value. Special derivative path for brushless excitation provides optimal response.

Field current regulator (FCR)

Field Current Regulation fulfills the usual requirement of manual control. FCR is a backup to the AVR in case of, e. g., fault in the stator voltage measuring circuits.

Reactive power controller (VAR)

The VAR controller keeps the reactive power constant. The reactive power is regulated by a slow operating three-state controller that adjusts the AVR's reference value. This maintains the favorable effects of the fast AVR during transient power line disturbances.

Power factor controller (PF)

The PF Controller keeps the power factor constant. The power factor is regulated by a slow operating three-state controller that adjusts the AVR's reference value. This maintains the favorable effects of the fast AVR during transient power line disturbances.

Test modes (FVR and FCS)

HyCon Thyricon features two test modes: Field Voltage Regulator (FVR) and Fixed Control Signal (FCS). The test modes are used for factory/commissioning tests and as a maintenance tool, as well.

Transfer between control modes

The commutation between VAR Controller, PF Controller, AVR and FCR can be requested by the operator or is accomplished automatically in case of specific faults. Any transition is smooth, so there are no perceptible generator terminal voltage transients ("bumpless transition").*

* Follow-up and bumpless transitions between control modes.

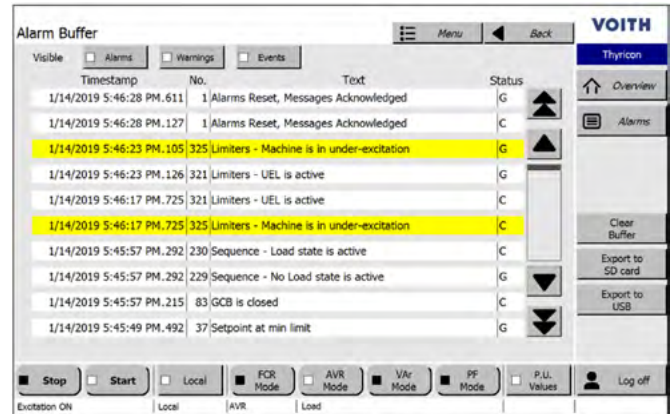

Alarms and events buffer screen are exportable as text files to USB or SD card directly from the operator panel

This includes for example:

- **Electrical brake**
- **Line charging and black start**
- **Back-to-back start**
- **Static frequency converter (SFC)**
- **Direct start/across-the-line**
- **Start field flashing, DC and/or AC**
- **Natural cooled or forced cooled thyristor converter**
- **Redundant thyristor bridge and controller**
- **Auto adjustment of reactive power after synchronism**
- **Reactive load shedding before disconnection from the grid**
- **Grid voltage follow-up**
- **Handling of external set points**
- **Selection of the control modes, rectifiers and controllers with follow-up and bumpless transfers**

Monitoring, control, supervision and protection

The regulator includes all necessary logical functions for control and supervision of the excitation equipment during startup, service and shutdown. Generator protection functions are also available in the regulator and can be adjusted as backup of the generator relay protection functions (VHz, stator overcurrent / overvoltage, field overcurrent / overvoltage, loss of excitation, etc).

Generator voltage measurement supervision

The generator voltage measurement signal and the supply voltage to the rectifier bridge can be supervised by mutual comparison. In the event of discrepancy, automatic change-over to FCR is initiated.

Alarm system

Each individual internal and external alarm is indicated in a local Human-Machine Interface. They can also be indicated with LEDs, relay contacts or on a remote control panel. The alarm signals are grouped into “Event”, “Warning” and “Alarm.” These message classes help operators to act immediately when necessary and plan accordingly the maintenance and corrective or preventive actions.

Self monitoring and diagnose

The programmable logic controller self-monitoring functions cover the power supply, processor, memories, I/O units and communication. Some of the supervision can be time-delayed, and this is necessary to obtain adequate voltage regulation during temporary network faults.

Limiters and control features

Upon voltage changes in the power system, the AVR will restore the stator voltage by increasing or decreasing the machine field current, and thereby also the reactive power. The higher the short circuit power of the electrical system compared with the machine ratings, the higher the risk of overloading the generator; this is due to high amounts of produced (overexcited) or consumed (under excited) reactive power.

The limiters have the task of preventing outages of the machine due to operation of the protection relays caused by reactive overloading, underexcitation, or overloading of the exciter.

HyCon Thyristor ensures the operation of the generator inside its capability curve

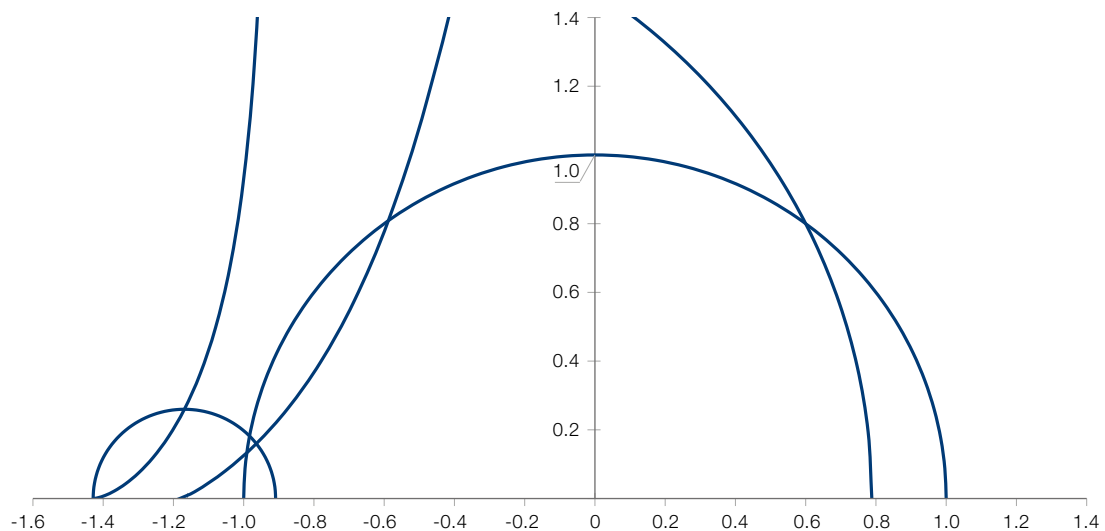

Reactive and active compensation or droop

In addition to the AVR structure, there are reactive and active droop compensators. (Droop), line droop compensation (LDC) and reactive differential compensation (RDC). These features compensate for active and reactive voltage drops in the step-up transformer and/or transmission line. The reactive droop compensation also helps in balancing the reactive power among synchronous machines that are connected in parallel or directly to the grid without a transformer in between.

Frequency compensation

Frequency compensation is used to help weak grids during transients. The generator voltage is changed in phase with the deviation of the frequency. The changes in the active power delivered to the weak grid due to the voltage changes help to damp the oscillations.

Reactive differential compensation (RDC)

The reactive differential compensation, also known as cross current compensation, compensates for the drooping voltage characteristic while enforcing reactive current sharing between synchronous machines sharing a common connection. The RDC is used to achieve stability of parallel units; it reduces reactive unbalancing between units and also provides reactive power support in case of short circuit in the power system. RDC can be used for up to four machines connected in parallel to the same step-up transformer.

Step response in the stator voltage and the resulting step in Q and the oscillation in active P

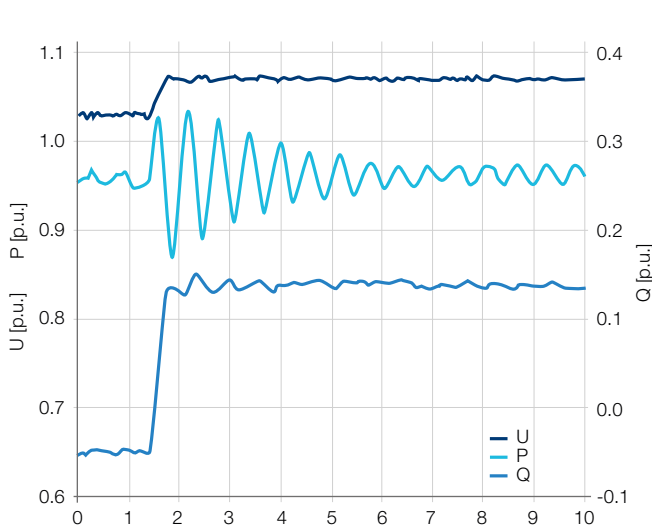

Volts per Hertz limiter (V/Hz)

The limiter, also called the flux limiter, reduces the voltage during under-frequency conditions. Two configurable limiters, an instantaneous and a time-delayed can be adjusted to protect the generating unit, especially the step-up transformer, against magnetic saturation.

Time-delayed overexcitation limiter (OEL)

The time-delayed overexcitation limiter primarily avoids overheating of the synchronous machine field winding. The OEL also prevents overheating of the excitation system's power part. The permissible duration of the field current overload is inversely proportional to the overload current level. The time delay limiter is implemented with every characteristic as defined by IEC 60255-3 and IEEE C37.112 for coordination with protection functions. The OEL allows time-delayed overloads of the generator unit that are required for the stability of the electrical system.

Instantaneous overexcitation limiter (OELf)

The instantaneous overexcitation limiter keeps the field current below a predetermined value. The OELf is mainly used to prevent the thyristor converter from overheating, because of its short thermal time constant.

Safe operation of the excitation system and of the generator guaranteed by the HyCon Thyristor limiters

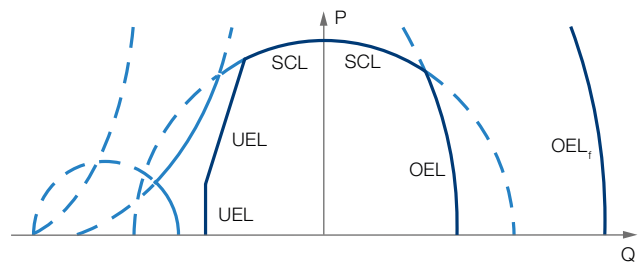

Control loops AVR and FCR have two different sets of parameters for NO LOAD and LOAD (four sets in total for each) and some limiters and functions, such as OEL, OELf, SCL, UEL and PSS have two sets of parameters; double set of parameters are available to allow a perfect adaptive control according to the grid conditions and customer requirements.

Underexcitation limiter (UEL)

The underexcitation limiter avoids operation conditions that would cause stator overheating or instability and loss of synchronism. The UEL action is determined by identified regions on the synchronous machine capability curve. The limiter region is programmed in the HyCon Thyricon’s logic controller and is coordinated with the loss of excitation function of the generator protection relay. The UEL curve is dynamically compensated by the voltage variation (linear or square), and it can be configured with up to six points.

Stator current limiter (SCL)

Stator current limiter avoids overheating of the stator due to a rise in the generator current. SCL detects the overcurrent and compares it with the reactive current to determine how the voltage regulator should act. An adjustable inverse time characteristic allows coordination with PSS and therefore increases the grid stability. The SCL is most useful following upgrades of the maximum turbine power without a corresponding increase of generator rating.

Rotor temperature limiter (RTL)

The rotor temperature limiter avoids overheating of the rotor winding. The RTL detects overtemperature and acts on the field current in order to decrease the field winding temperature. The RTL detects overtemperature and acts on the field current in order to decrease the rotor winding temperature.

Grid voltage follow-up

Also known as pre-synchronization, the line (bus) voltage is used as a reference value for the voltage regulator during synchronizing. The voltage regulator will then keep the stator voltage equal to the grid voltage during the synchronization phase. This not only decreases the synchronization time, but also reduces transients upon closing the generator breaker.

Power system stabilizer

HyCon Thyricon features the dual-input integral of the accelerating power PSS2C and the multiple band power system stabilizer type PSS4C. Four separate bands respectively dedicated to very low-, low-, intermediate, and high-frequency modes of oscillations can simultaneously be damped by the PSS. The PSS models are compatible with the ones described by the IEEE 421.5 Standard. Generator-compensated frequency is available to be used as input for either PSS type. It is calculated to correctly emulate internal generator voltage and generator shaft mechanical oscillation improving effectiveness of PSS damping action.

Programmable logic controller (PLC)

HyCon Thyricon’s hardware platform is based on programmable logic controllers, PLC. Digital and analog input/output cards as well as communication modules for serial communication are available for internal and external interfaces. The equipment is normally mounted in a cubicle together with power supply units, transducers and interface relays.

HyCon Thyricon enhances the stability of the electrical system through the use the IEEE 421 dual-input power system stabilizer (PSS2C) shown in diagram below.

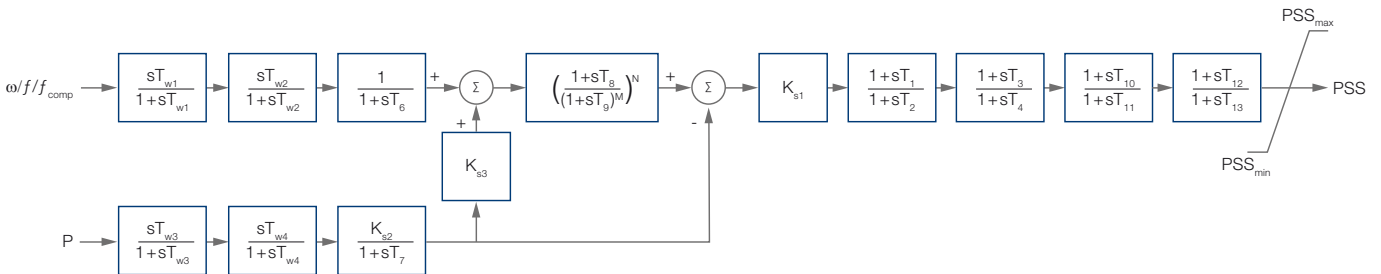

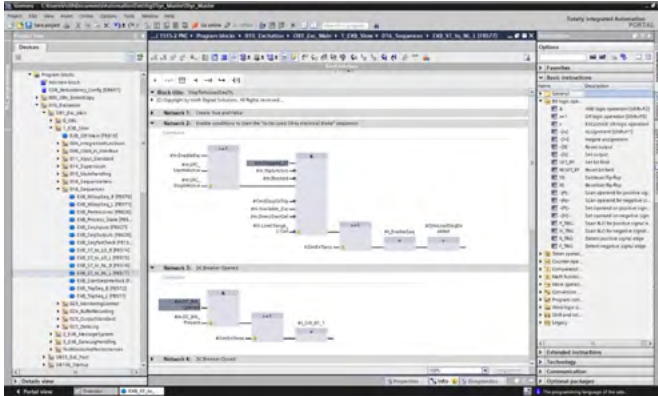

Graphical user-friendly software with possibility to switch programming languages – function block diagram (FBD)

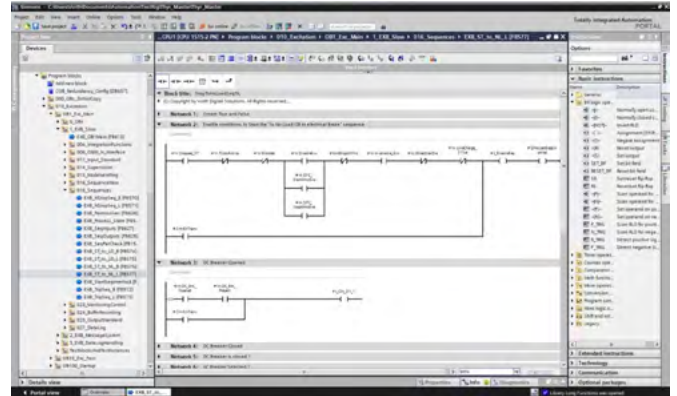

Graphical user-friendly software with possibility to switch programming languages – ladder (LAD)

Application software

The software modules incorporated in the voltage regulator are structured to provide a very clear and detailed view of the modules included. All analog signals are scaled in the per-unit system (1 pu= 100 %).

The software modules are built up from function blocks from a library according to the Standard IEC 61131-3. Examples of function blocks are AND-gates and SR-flip-flops, arithmetic blocks, control and filter blocks, timers and oscillators.

The function blocks are interconnected to obtain the required functions in the program module. The function blocks contain parameter inputs for setting of gains, limit values, time delays, etc. The software is coded using tools that provide object-oriented programming and full integration between controller and HMI.

Industrial off-the-shelf programmable logic controllers guarantee worldwide access to maintenance and spare parts. The Siemens s7-1500 PLC illustrated in the picture is one application example; other PLCs are available on request.



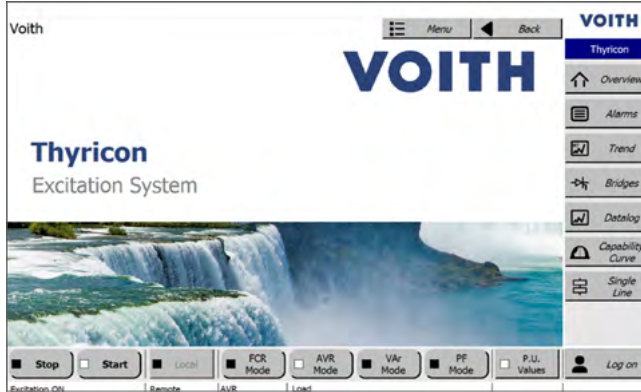

User-friendly operator panel with touch-sensitive color LCD screen

Communication protocols

The voltage regulator can operate as a stand-alone unit with communication to all types of joint control and remote control equipment via parallel digital and analog signal interface. Serial communication with different types of protocols can be included. The programmable logic controller takes care of the excitation system and only a few input/output signals are needed.

Control Panel or Human-Machine Interface (HMI)

HyCon Thyricon is fitted with a local operator panel (HMI) available in different sizes usually mounted in one of the cubicles' front doors. The operator panel features a touch sensitive color LCD screen. Different user levels with different passwords allow access to the different functions of the operator panel.

As a safety precaution, HyCon Thyricon incorporates a command confirmation system. All frequently used commands that directly effect the status of the system are subject to a two-stage operation sequence.

Typical input and output signals

- Excitation off / on
 - Selection of control mode
AVR/VAR-controller / PF-controller
 - Decrease/increase signals for set-point adjustment
 - Signal for closed generator circuit breaker
 - Speed > 90 %
 - Limiter in operation
 - Excitation "Ready to Start"
 - Common signal "Warning"
 - Common signal "Trip Request"
-

The chance of incorrect operation is reduced by a two-staged command confirmation system incorporated in the operator panel.

User-friendly operator screen

The HyCon Thyricon user-friendly human-machine interface provides information about the general status of the excitation system and the measured generator data. Active control and operation mode, as well as the current state of the system, can be seen in the corresponding output fields.

Local and remote interlocking of commands

HyCon Thyricon can be operated remotely from the control room or locally from the human-machine interface. The set points of the control modes can be locally changed, if necessary. Local and remote mode commands are safely interlocked so the maintenance staff is protected from dangerous remote commands during inspections and service.

Simulation

HyCon Thyricon incorporates powerful commissioning, testing and maintenance tools into the human-machine interface. Monitoring of digital and analog inputs and alarms is accessible to all users. Forcing of input, output and alarms is protected by password. A simplified generator model implemented in the controller is available for closed loop simulation and dynamic tests.

Block diagram and parameter changing

HyCon Thyricon parameters are accessible through the operator panel and can be changed online without any system operation interruption. The parameters are organized in self-explanatory groups. Accidental changes are avoided by minimum and maximum limits, command confirmation and/or password protection. The parameter list with the actual values can be exported as text file to a USB or SSD card directly from the operator panel.

Data logging

HyCon Thyricon's human-machine interface incorporates a powerful data logging tool. The number of samples, the sampling time and the number of analog values to be logged are configurable. Various events and analog values can be selected as trigger to the data logger.

The data logging configuration is performed through the human-machine interface, but the actual data is stored in the PLC. In this way, the last data trends will not be lost even in case of power outages.. The data logging tool can be adjusted to permanently store the events related to the last emergency shutdown. The stored data can be viewed in the operator panel.

The parameter changing and the data logging capabilities enable the commissioning of HyCon Thyricon without any external tool. The recorded analog and digital values can be exported as text file to a USB or SSD card directly from the operator panel. The number of data logs stored in the PLC is limited. A PC-based software tool is available on request for retrieving, analyzing, reporting and storing the data logs.

Special test tools

HyCon Thyricon includes a maintenance tool for testing Frequency Response, Step Response and Pseudorandom Binary Sequences (PRBS). All of these tools are available from the local panel.

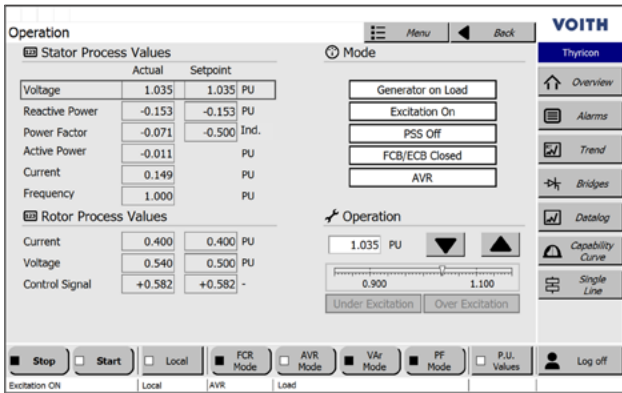

User-friendly main screen for operation and maintenance

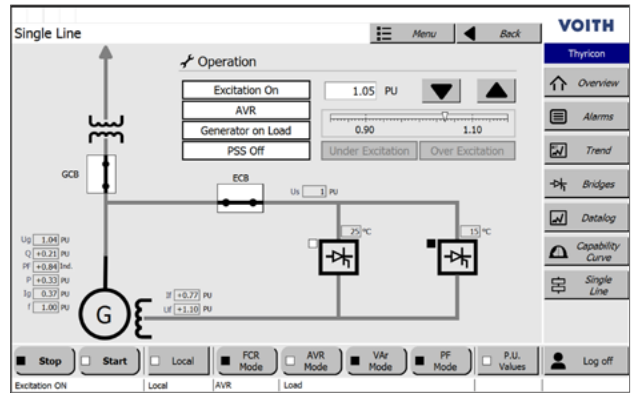

Clean and meaningful single line screen with excitation equipment status information

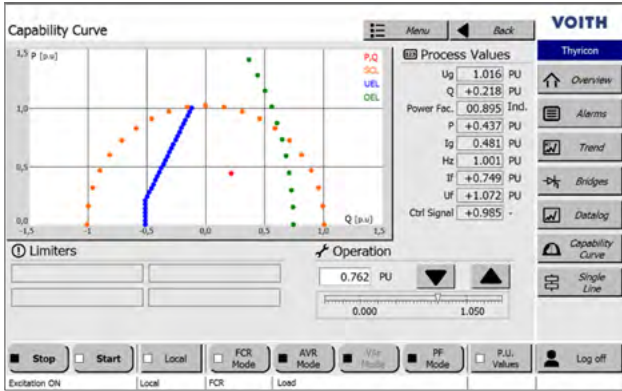

Dynamic capability curve with the indication of the operation point and HyCon Thyricon Limiters

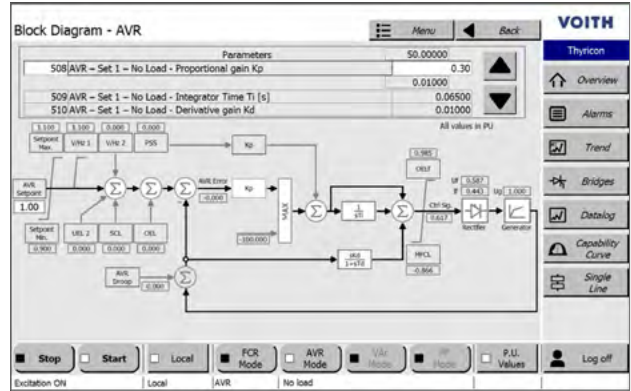

Transfer functions screen with a real and iterative representation of AVR Loop, access to all parameters and allowance of parameter changing from the operator panel

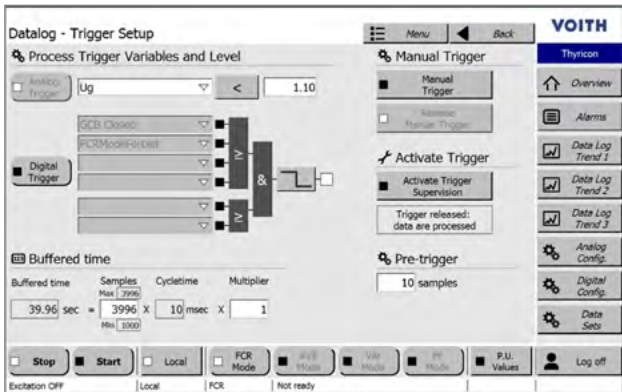

Highly flexible data logger can be configured to record machine and excitation behavior during any condition, such as a trip or an electrical transient

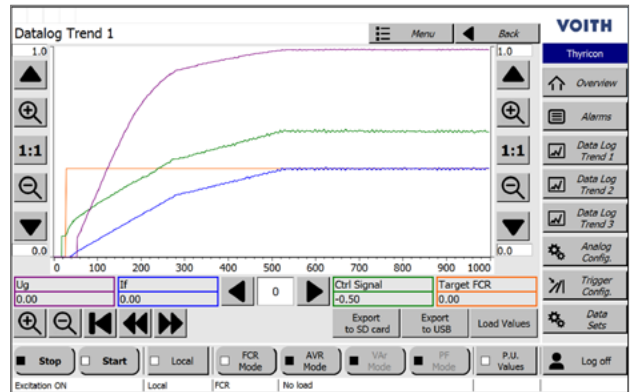

Built-in data logging and real-time trend from the operator panel allow testing of the system without external loggers or computers

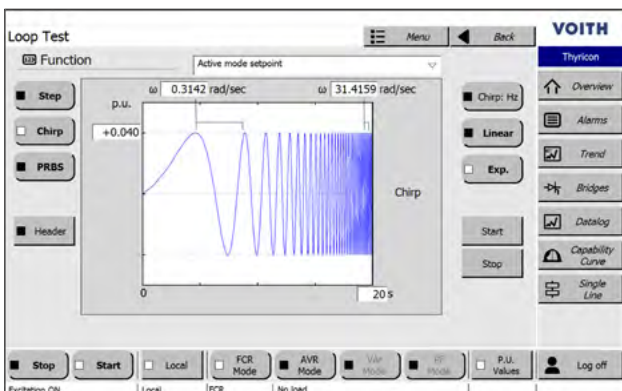

Waveform Generator: HMI integrated tool for frequency response, step response and PRBS analyzes

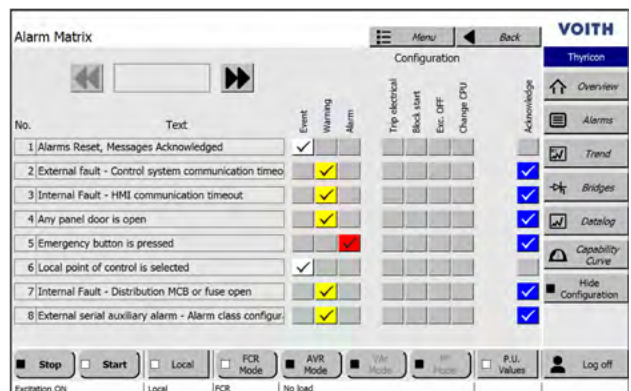

Configurable Alarm Matrix, available from the operator panel

Static excitation system

Static exciters are used for synchronous generators in all types of power generating plants: hydro, thermal, gas, diesel and wind, as well as for synchronous condensers and motors.

The advantages are summarized in the following main points:

- Superior dynamic control characteristics
- Low losses
- The size is not dependent on the speed of the machine for a given excitation power

The power circuit

The main power circuits included in the static excitation system consist of:

- Excitation transformer
- Thyristor rectifier bridge
- Equipment for de-excitation
- Equipment for field flashing

The excitation power is normally derived from the machine terminal bus and is conducted via the rectifier bridge into the field winding of the synchronous machine. Power necessary for voltage build-up at start is supplied via the field flashing equipment.

The excitation power can also be derived from the local power supply or from a suitable point outside the machine circuit breaker. As the connection point is normally energized, no field flashing equipment is required. During de-excitation, the field breaker is opened and the field of the machine is de-energized.

High ceiling voltage capacity and a wide-range operating voltage of the firing card guarantee that HyCon Thytricon continues to work even during severe voltage drops in the electrical system.

Excitation transformer

The purpose of the excitation transformer is to adapt the power supply voltage to the converter and to isolate the field winding from the power supply. The transformers are sized by our experts to meet the most demanding requirements from customer around the world, compliant with regional and global standards.

In most of the static excitation systems, the rectifier bridge is fed by the generator itself.

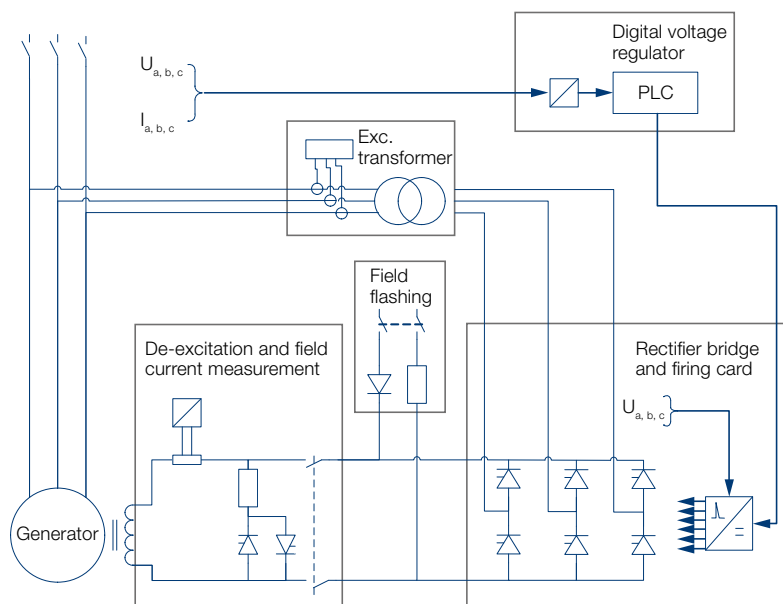

Thyristor rectifier bridge

The converter, a fully controlled bridge, consists of a thyristor stack, firing card and the necessary equipment for supervision and cooling. Each thyristor stack is connected as a three-phase, six-pulse bridge. This connection allows the converter to operate as a rectifier as well as an inverter.

The thyristors are protected against short circuits by means of a quick-acting fuse in each branch or phase. Protection against voltage transients is achieved by RC circuits (snubbers). For efficient cooling, the thyristors are clamped into heat sinks that can be natural, or more demanding systems can have closed loop cooling upon request. The thyristor converter is controlled by the digital voltage regulator via the firing card. This card converts the output signal from the regulator to trigger pulses, with correct phase shift compared with the supply voltage.

The supply voltage is determined by the required ceiling voltage from the thyristor converter and is adapted to machine data in each individual case. The ceiling voltage is critical for the transient response of the generator voltage, and thereby the contribution from the generator to the voltage stability in the power line during disturbances. The ceiling voltage can be tailored for customer and grid authority requirements. The thyristor converter is sized for the continuous field current necessary for maximum long-term load on the machine.

It should also be able to carry the field forcing current received at ceiling voltage as described above. The normal field forcing time is 5 to 60 seconds, depending on project specifics. To achieve higher reliability, the excitation equipment can be supplied with redundant thyristor bridges. Redundancy is either performed as a 1 + 1 system with one bridge in operation and the other one in hot stand-by or as an N + 1 system from which one bridge can be disconnected. In case of a 1 + 1 system, each bridge is designed for rated load. In case of an N + 1 system, the bridges are designed for rated load with one bridge out of service.

Field flashing

When the excitation equipment is supplied from the generator terminals, it is necessary to supply the field winding of the machine with a small current for a few seconds to initiate the voltage build-up. The special circuit for field flashing feeds current into the field winding until the voltage of the generator through the excitation transformer is sufficient to supply the converter.

HyCon Thyristor only needs an exceptionally low field current during field flashing, reducing the burden on battery systems. This is due to wide-range HyCon Thyristor firing card. The start-up energy is normally provided by the station battery. Another solution available is to obtain the start-up energy from the station AC power supply via a transformer and a diode rectifier bridge.

Examples of a HyCon Thyristor static excitation system



De-excitation

Special measures have to be taken to break the DC current and discharge the energy stored in the field winding of the machine. Otherwise very high voltages occur, which can damage both the excitation equipment and the rotor winding. In case a generator electrical fault should occur, it is also very important to de-excite the generator as fast as possible.

Two different methods can be offered:

- De-excitation is performed by an excitation circuit breaker connected on the AC or DC side of the converter, and a de-excitation thyristor connected in series with the de-excitation resistor on the DC side parallel to field winding.
- De-excitation is performed by a DC field breaker with a make-before-break pole. The breaker disconnects the rectifier from the field winding.

The de-excitation resistor can be delivered both as linear and non-linear type. The non-linear type is voltage dependant and de-excites the last third of the field energy faster than a linear resistor. De-excitation during normal unit shutdown is achieved by reversing the field voltage. The excitation breaker is opened when the field current is zero, reducing the wear on breaker poles.

Field circuit overvoltage protection

The purpose of the field overvoltage protection (crowbar) is to prevent excessive voltages in the field circuit that might otherwise arise during certain unfavorable transient fault conditions, such as incorrect synchronization or loss of synchronism. The overvoltage protection is incorporated in the de-excitation equipment. It consists of two thyristors connected in anti-parallel in series with the discharge resistor and a overvoltage detection device (ODD). The ODD triggers the thyristor fires when the voltage in either direction across the field winding exceeds the protection level chosen with the triggering unit and short-circuits the field winding through the discharge resistor. The ODD is an independent device, which doesn't need power supply to work and has fast response in the order of micro seconds.

Protection

In addition to the protection for different parts of the main circuit described above, dedicated devices, built-in functions or standalone relays protecting against the following are available:

- Excitation transformer overcurrent / short circuit
- Excitation transformer overtemperature
- Rotor earth fault
- Field overcurrent

Example of a HyCon Thyricon brushless excitation system



The wide-range operating voltage of the firing card allows HyCon Thyricon to start only with the remanent voltage. Nevertheless, field flashing is a must, as the remanent voltage may be zero after long periods without operation.

Brushless excitation system

On some generating units, the excitation system is realized with a rotating electrical machine. Voith also has products in the portfolio to cover customer requirements for this application, its VBE series. The main advantage of this solution compared to DC rotating exciters and small size static exciters is that the problems associated with the commutator and brushes can be completely eliminated. The brushless system eliminates the slip rings and thus all current-carrying brushes, preventing carbon dust issues. Footprint is also reduced; as all power parts are rotating with the generator, only a small voltage regulator is required. The brushless excitation system can be used for any synchronous generator.

Main components

The main power circuits included in the brushless excitation system consist of:

- Power supply
- Rotating diode rectifier
- Digital voltage regulator with small rectifier module
- Rotating brushless exciter

The excitation power is normally derived from a PMG (a pilot AC exciter of permanent magnet type) and is conducted via the controlled converter equipment into the field winding of the main exciter.

The excitation power supply can also be derived from the local power supply or the generator terminal bus via a suitable transformer for isolating and voltage adaptation. With supply from the generator terminals, power for voltage build-up at start must be supplied via field flashing equipment. The controlled rectifier supplies adequate excitation power to the field winding of the synchronous generator. The rotating diode rectifier does not allow the main exciter to supply negative voltage or current to the generator field. During de-excitation, the exciter field breaker is opened and the exciter field is de-energized through the discharge circuit. The field winding of the synchronous generator is then de-energized through the diode rectifier mounted on the generator shaft. The AVR consists a controller with a small power converter based on a one- or two-quadrant DC chopper.

Protection

Common protections and supervisions that are available:

- Detection of diode faults in the rotating rectifier of the main exciter
- Field overcurrent protection
- Earth fault protection; to be connected to an auxiliary slip ring in the main generator field
- AVR converter failure

Voith HyCon brushless excitation system diagram

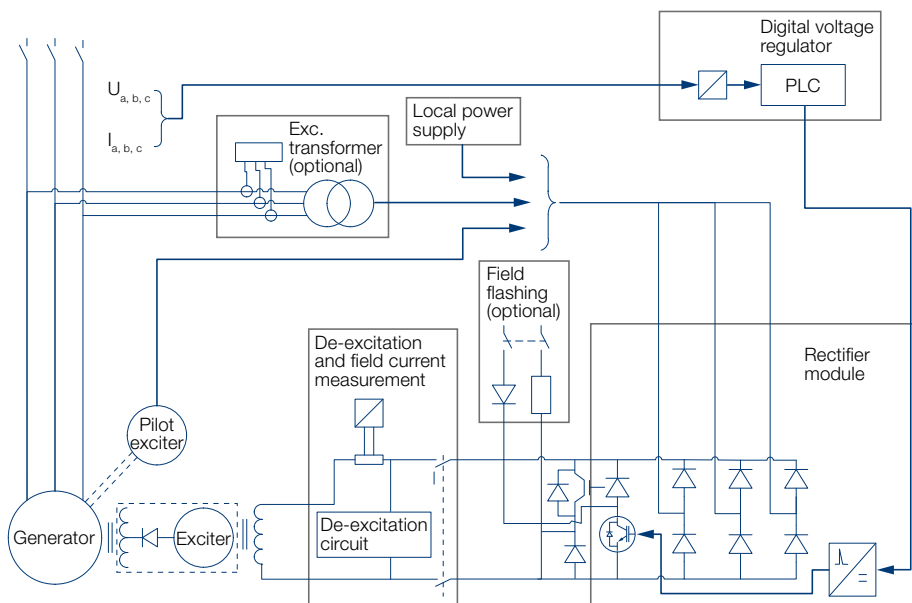

Documentation and quality assurance

The excitation system is described in a set of instructions and drawings. Additional documents can be delivered depending on project requirements.

- Operation and maintenance manual with
 - Technical specification
 - Equipment ratings
 - Functional description
 - Operation instructions
 - Troubleshooting guide
- Layout
- Circuit diagram
- Test report

The specification, design, manufacturing, testing and commissioning of the voltage regulator as well as the complete excitation system are executed under high quality standards and requirements. Prior to delivery, each system is subjected to a test and verification procedure. The verification covers every unit according to a pre-defined inspection and test plan.

HyCon Thyristor has undergone evaluation by independent third-party companies specializing in power system control. It was tested and evaluated in depth through hardware-in-the-loop simulation. Results were compared with mathematical models from an independent simulation tool. HyCon Thyristor meets or exceeds the most stringent requirements for high initial response excitation systems for both rotating and static applications. The implemented control loops can be fully modeled with IEEE 421 predefined models.

Technical data

General data for control and regulation circuits. Concerning data for main circuit, please see specification available for the project.

Technical data

Auxiliary / electronics supply voltage	DC	24 V or 48 – 250 Vdc
	AC	110 – 240 Vac
Measuring circuits	Voltage 1, 2 or 3 phases	Max. 500 V
	Current, 1, 2 or 3 phases	Max. 100 A per 1 s
	Frequency	50 / 60 Hz
	Load	< 0.1 VA / phase
Regulating accuracy	–	+/- 0.1 %
Ambient temperature	Storage	-40 – +70 °C
	Operation	0 – +50 °C
Protection degree	With self-cooled bridges	Max. IP32
	With forced cooling	Max. IP43
	With air-water heat exchanger	Max. IP54
Environment conditions	No condensation permitted	95 % (space heaters will be added as required to reach this)
	Rodents and termite free	–
	Up to 1 000 m. a. s. l.	Higher altitudes on request
Power section input	Voltage range	5 – 2 000 V
	Frequency	5 – 500 Hz
Applicable codes	IEEE Std. 421.1-2007	Criteria and definitions
	IEEE Std. 421.2-2014	Guide for identification of dynamic performance
	IEEE Std. 421.3-2016	Standard for pigh-potential test requirements for excitation
	IEEE Std. 421.4-2014	Guide for the preparation of excitation system specification
	IEEE Std. 421.5-2016	Excitation system models for PSS-studies
	IEC 60034-16-1 (2011)	Excitation systems for synchronous machines

References in recent years

2013 Lanforsen, Sweden

4 x 14 MVA, Thyricon 400

2013 Agua Vermelha, Brazil

5 x 250 MVA, Thyricon 500

2014 Ingula, South Africa

4 x 373 MVA, HyCon Thyricon 600

2014 Beyhan I, Norway

3 x 235 + 1 x 38 MVA, HyCon Thyricon 600

2015 Red Rock, US

3 x 27 MVA, HyCon Thyricon 400

2015 Teles Pires, Brazil

3 x 404 MVA, HyCon Thyricon 600

2016 Stornorrfors, Sweden

3 x 155 MVA + 1 x 206 MVA, HyCon Thyricon 300

2016 Paute Molino, Equador

5 x 111 MVAm, HyCon Thyricon 500

2017 Yacyreta, Argentina

2 x 172.5 MVA, HyCon Thyricon 600

2017 Coe, Belgium

6 x 230 MVA, HyCon Thyricon 600

2018 LTK, Thailand

2 x 282 MVA, HyCon Thyricon 500

2018 Tarbela 4, Pakistan

3 x 522 MVA, HyCon Thyricon 600

1 Red Rock, USA

2 Tarbela, Pakistan



Voith Group
Voith Hydro Holding GmbH & Co. KG
Alexanderstr. 11
89522 Heidenheim, Germany

Contact:
Phone +49 7321 37-9990
digital-hydro@voith.com
www.voith.com/digitalhydro

A Voith and Siemens Company



VOITH
Inspiring Technology
for Generations