

Voith StreamDiver®

Reliable Performance for Low
Head Hydro Power Plants



Voith StreamDiver®

Setting New Standards for Operations

The StreamDiver turbine technology combines innovative design, long operational history, and world class experience in hydro turbine engineering within Voith. While the engineering knowhow ensures high quality and performance standards, new innovations tackle the specific requirements of low-head hydro projects. Through the combination of knowhow and innovation, the StreamDiver ensures reliable operation and predictable revenue streams, minimal maintenance, and reduced service complexity compared to conventional technologies. All this, while setting new standards for the ecological production of electricity.

As-Built Configuration in Nussdorf, Austria

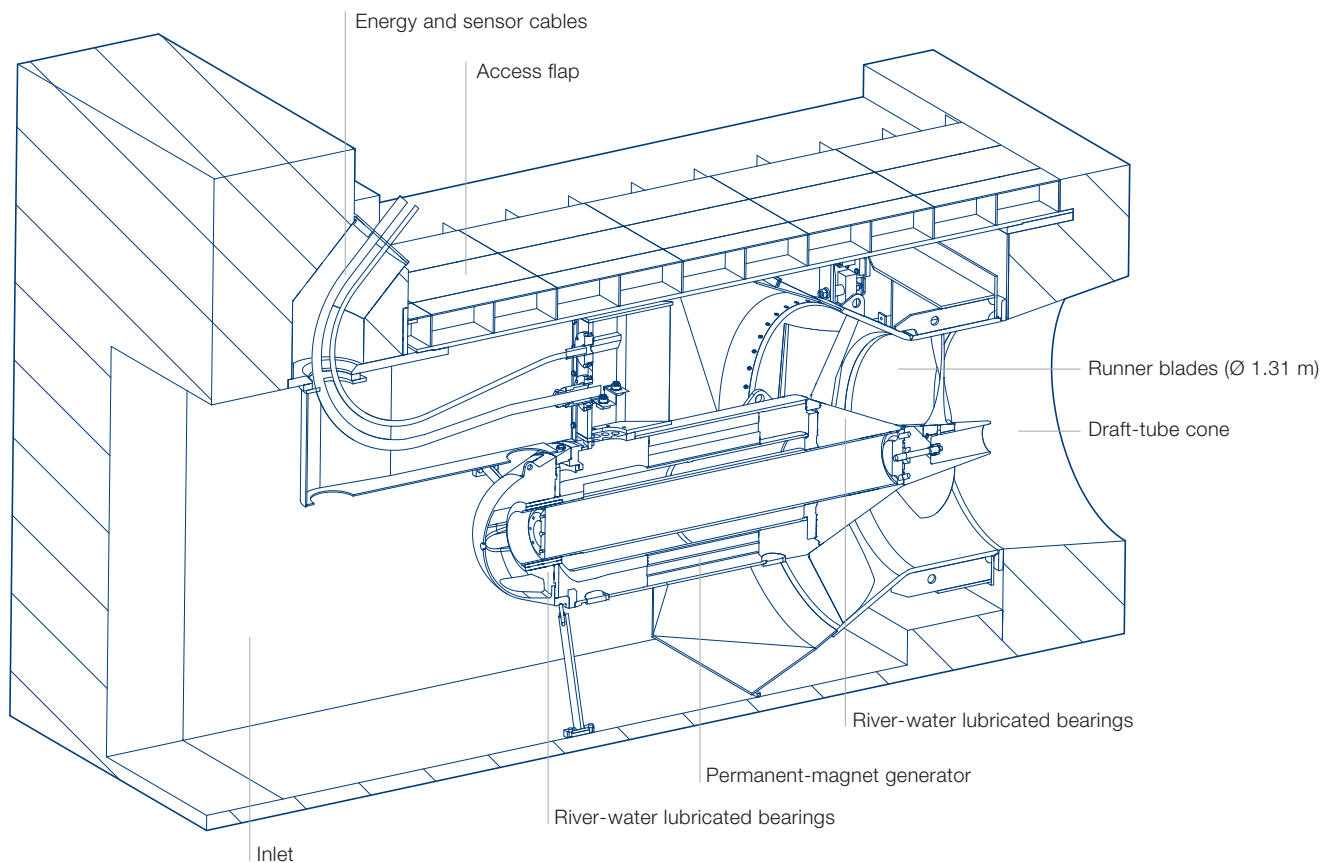



A StreamDiver[®] Showcase Project

Nussdorf plant, Austria

The historic site Nussdorf is located on the Donaukanal near the heart of Vienna. Due to the construction of a larger hydro-power plant on the Danube river in the mid 1990's, the water levels at Nussdorf site were raised and potential for power generation became available. Finally in 2005, the site has been first utilized for power generation with a total capacity of 5 MW. In 2011, the utilities VERBUND, EVN, and Wien Energie jointly decided to test a new turbine technology in their existing plant – the StreamDiver.

After project development and manufacturing, the StreamDiver unit was commissioned in August 2012. Since then, operation has been nearly continuous with only one planned inspection after the first 12 months of operation. While the initial demonstrator project has been planned for two years, the overall success persuaded the owners to extend operation through 2014. As of today, the unit is still online. So far, the StreamDiver has required no maintenance while supplying continuous power to the grid, completely oil-free and with a stable performance.

Project Data

Project Name	Nussdorf
Operator	Verbund, EVN and Wien Energy
Location	Nussdorf, Vienna, Austria
Status	in operation (since Aug '12)
Unit Type	SD 13.10
Generation Type	PMG, 333 rpm
Rated Head	3.58 m (11'9")/Max. Head 4.68 m
Rated Discharge	9.96 cms
Rated Output	314 kW/Max. Output: 450 kW
Operation	fixed-speed/variable speed (FPC as Option)

History / Milestones

- July 2011: Project kick-off (contract signed)
- May 2012: Public presentation of project
- August 2012: Installation and commissioning completed
- July 2013: Planned inspection (after 12 month of prototype operation)
- August 2013: One year anniversary celebration
- May 2015: ~24,000 operating hours cumulated
- July 2015: 3 years of maintenance-free operation



3

- 1 Historic Nussdorf site near Vienna, Austria
- 2 StreamDiver unit during installation
- 3 StreamDiver in service position

Network Connection of StreamDiver® Unit in Nussdorf

Full power converter as option to test variable speed operation

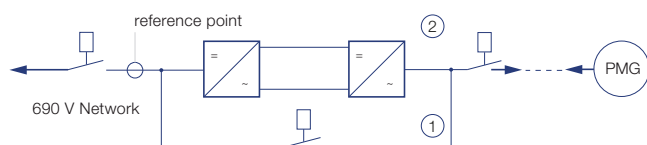

- ① Direct connection to grid (standard)
- ② Connection with frequency converter (optional)

Start Sequence without Frequency Converter

Synchronization is controlled by shut-off valve (discharge)

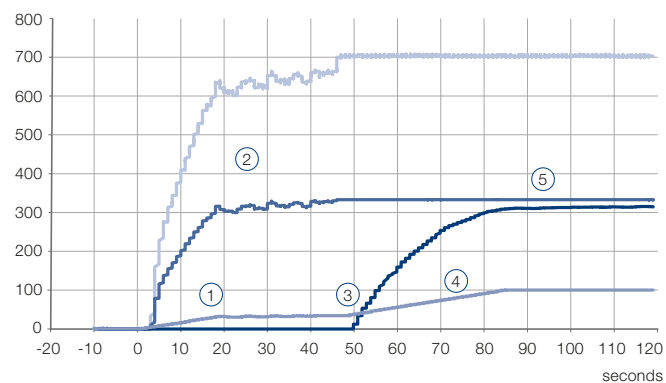

- ① Start is initiated by opening the shut-off valve partially
- ② Machine starts running, speed and voltage reaches rated conditions
- ③ Synchronization unit is active and closes circuit breaker
- ④ Shut-off valve is opened to 100 %, power output increases
- ⑤ Start procedure finished

More than 24,000 operating hours producing over 7 GWh have successfully proven the innovative concept.

Operational Statistics (status: May '15)

Operating hours	> 24,000 hrs
Exported electricity	> 7.0 GWh
On-site inspections	1 (Downtime: 1 day)
Maintenance services	0
Intake cleaning method	Automated flushing (during operation) ~1 / week

Stop Sequence – Normal Stop by Shut-off Valve

Shut-off valve closes and stops unit automatically

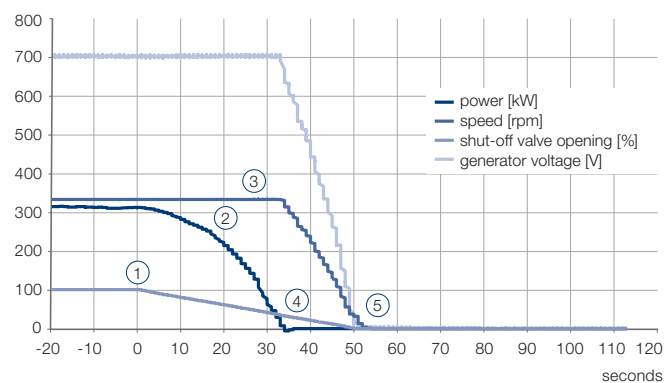

- ① Shut-off valve gets stop command and slowly starts to close
- ② Discharge and therefore power output is decreasing
- ③ Machine is running at stable speed and voltage (synchronized to grid)
- ④ Power output is decreased to zero, circuit breaker opens; machine speed and voltage is reduced while valve closes
- ⑤ Stop procedure finished



4



5

4 Assembled thrust bearing pads

5 Lowering the pre-assembled generator unit

At a Glance: Operation & Maintenance

Meeting the requirements for hydro at a smaller scale

In many regions around the world, low head hydro is gaining attention for its significant potential in the hydro sector. Still around 85 percent of the dams in the world have not been utilized for power generation. With the majority of these sites are at lower heads, there is tremendous potential for decentralized production and a contribution to a sustainable renewable energy mix in the future. However, in many ways low head hydro differs from its larger cousin. Beside the needs of minimizing investment costs, the decentralized operation at smaller scales raises new requirements to reliability and maintenance.

Planned Inspection & Maintenance Activities

Typical Kaplan bulb versus StreamDiver®

Components/Systems subject to inspection and service	Kaplan	StreamDiver®
Lubrication oil	x	
Lubrication oil filters	x	
Distributor moving parts (e.g. springs and bushings)	x	
Runner moving parts (e.g. seals and servomotor)	x	
Shaft seal	x	
Generator	x	x
Bearings	x	x
Accessories	x	x*
Functionality of sensors	x	x**

* In comparison reduced number of accessories

** In comparison reduced number of sensors

The StreamDiver technology is meeting those requirements through its unique design. All relevant operational parameter and system states can be condition-monitored remotely and manual inspection is reduced to a minimum. Furthermore, the minimization of moving parts and support systems lowers the complexity of inspection works and, as a result, maximizes the availability of the unit. Highest performance, stable operations, long service intervals, reduced downtime, and low costs for spare parts ensuring a stable revenue stream over the project's lifetime.

The StreamDiver® O & M Features

Maximizing energy production and minimizing total lifecycle cost

Operation

- + high hydraulic performance
- + high efficiency of the permanent magnet generator
- + oil-free operation, no pollution of environment
- + submerged turbine generator unit, no visual impact

Comprehensive Condition Monitoring

- + reduction requirements for manual inspection
- + planned and scheduled activities

Reliable Design and Reduced Number of Components

- + longer service intervals
- + reduced requirements for inspection & maintenance actions
- + reduced complexity for service and minimized downtime
- + low costs for spare parts

Voith Hydro Holding GmbH & Co. KG
Alexanderstrasse 11
89522 Heidenheim, Germany
Tel. + 49 7321 37-0
Fax + 49 7321 37-70 71
www.voith.com

A Voith and Siemens Company

VOITH
Engineered Reliability