

Voith Paper

VOITH

**EcoSoft™ calenders: for the complete range
of soft nip calendering**



Voith – Our company

Voith is a reliable partner to essential industries. We set standards worldwide for paper making technology, power transmission, power plant equipment and for industrial services. With annual sales of approx. € 3.3 billion, 24,000 employees and 180 locations worldwide Voith is one of the large family-owned companies in Europe.

We want to be our customers' preferred supplier and business partner



Quality, reliability and soundness are key concepts of our identity.

These are expressed in three words:

Voith – Engineered reliability.

Our markets are the markets of the future

The world's demand for paper, energy, mobility, automation and technical services will continue to grow over the next few years. Voith will participate in this coming growth.

Pioneering innovations from Voith – to our customers' advantage

1869 1st Voith patent (Refiner)	1873 1st Voith Francis turbine	1903 Niagara (largest turbines at the time)	1922 Kaplan turbine	1927 Voith-Schneider- Propeller	1929 Voith turbo transmission	1952 Voith water tractor, Voith automatic transmission (DIWA)
--	---	--	-------------------------------	--	--	---

The engine of our strong growth: innovative power and reliability

Voith has operated in the black since its founding on January 1, 1867. The dynamic development and the growth over the last few years confirm that we have taken the right steps.

Voith engineers have again and again written new chapters in the history of technology. Today, Voith holds over 7000 active patents worldwide. Approximately 400 new ones are added every year.

Business relations – spanning generations



For example, since

1897	Zanders, Germany (Paper)
1904	Scheufelen, Germany (Paper)
1905	Haindl, Germany (Paper)
1909	Yunnan Power, China (Hydro)
1914	EnBW, Germany (Hydro)
1930	Bodensee-Schiffsbetriebe, Germany (Marine Technology)
1950	Renault, France (Turbo)
1955	MAN, Germany (Turbo)

We will continue to expand our worldwide dedication to our markets. The fundamentals of our dealings are the values and long-term strategies of Voith, one of Europe's large family-owned companies.

1965

Turbo reversing transmission for shunting locomotives

1985

1st Voith Vorecon

2001

One Platform Concept for the paper production process

1960

Hydrodynamic brake, flotation deinking process

1978

Itaipú (largest hydro power plant in the world)

1995

Fishfriendly turbine

2002

Aquatarder

Good for your paper: EcoSoft™ calenders from Voith Paper ensure quality and productivity



The One Platform Concept covers all the steps in the paper manufacturing process with its modules proven in production.



Very good printability, optimum runnability as well as optical properties such as gloss and smoothness; these main requirements for modern papers are fulfilled by soft nip calendering. For this process EcoSoft™ calenders from Voith Paper provide a wide range of technology for the online calendering of papers.

As a leading supplier to the paper producing industry, Voith Paper recognized at an early stage the importance and advantages which result from its comprehensive system expertise. The One Platform Concept was developed with a view to customers' needs; this concept aims at maximizing profitability while at the same time assuring high quality standards. The modules in this technology concept take the entire process of papermaking into consideration, from fiber to end product. Thus the One Platform Concept provides the respective most profitable production line for every paper grade.

One of the essential modules for the final quality of papers is the calender. The EcoSoft™ calenders from Voith Paper permit implementation of a wide spectrum of calendered paper grades, from standard newsprint through uncoated and coated printing papers to special papers. The various EcoSoft™ technology concepts are presented on the following pages.

The EcoSoft™ family: tailor-made technology concepts for your production requirements

Since their introduction in the mid 80s, soft calenders have increasingly replaced machine calenders in production lines, and with good reason. While machine calenders give the paper a constant caliper but uneven density due to the hard nip, paper webs get an even density with slightly varying caliper due to the elastic nip in the soft calender. Soft calendered papers are much more suitable for printing due to this less harsh and more even compression; they demonstrate better runnability in the printing machines and at the same time, better printability resulting in improved print quality.

Today the EcoSoft™ range of calenders starts with pilot calenders with 50 cm working width through to production calenders with over 10 meters width, achieving highest line loads and surface temperatures as well as design speeds of around 2,200 m/min. Voith has developed various technology concepts for the EcoSoft™ family in order to be able to specifically run this wide range of applications:

EcoSoft™ Delta and EcoSoft™ Modular are used as standard applications which allow operation of the entire range of production requirements. Other frame types such as EcoSoft™ L or EcoSoft™ U are also used project-specifically.

These technology concepts are generally effected as 1-nip solutions with two rolls or as 2-nip variants in 2+2 roll layout depending on requirements. Layouts with three rolls are also implemented in individual cases for certain papers which are to be upgraded on one side.

The latest member of the EcoSoft™ family is the EcoSoft™ Delta with Nipco™ technology. This new soft calender concept can be used for all paper widths and medium to high calendering requirements. It takes up on elements from the successful Janus™ MK 2 and is distinguished by its good accessibility and easy roll change. The innovative DeltaLock™ system permits rapid and safe roll change even with large machine widths.

*Various EcoSoft™ calenders,
here mainly in the shop-assembly*



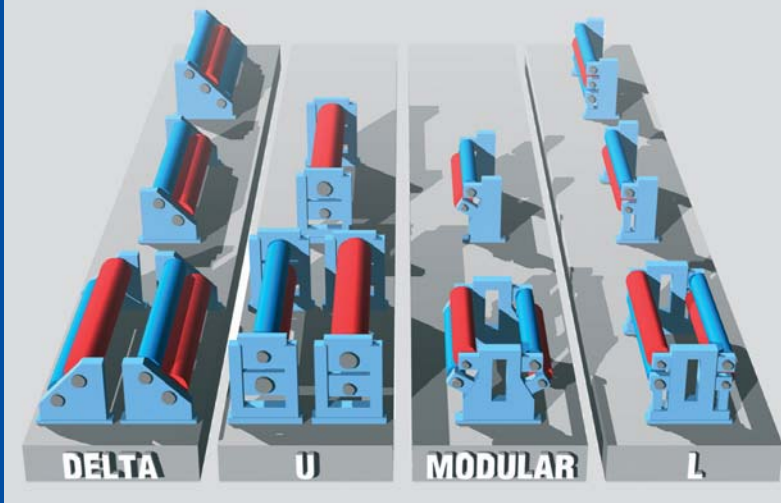

Voith has developed a market-oriented, modular calender concept in the EcoSoft™ Modular which specifically serves a wide range of paper grades in small and medium-scale installations.

EcoCal™ calenders are the variants with hard rolls, the so-called machine calenders. These are frequently used for CD-profiling, using either Nipcorect™ rolls or using external profiling devices such as ModuleTherm™.

The Caltronic™ calender control system makes the advanced technology of the EcoSoft™ calenders simple, sure and easy to operate. The modular control concept can be designed for the needs of any installation and keeps all additional options open to the operator. The problem-free data integration means that the user is provided with all the production-relevant data clearly and in real-time.

For the highest demands, such as in the case of rotogravure papers and the highest operating parameters, the calender concept of the Janus™ MK 2 from Voith offers tailor-made layout variants for optimum quality and productivity.

Standard values for the use of EcoSoft™ calenders				
Paper type	Grade	Calender configuration		
		1 x hard	1 x soft	2 x soft
Newsprint	3.5 – 6.0 PPS	(●)	●	●
SC-C	2.5 – 3.5 PPS			●
SC-B	1.8 – 2.5 PPS			●
Coating base paper	Various grades	●	(●)	
LWC film coated	40 – 50 Gardner			●
Wood-free coated	50 – 65 Gardner			●
Copying paper	150 ml/min Bendtsen		●	●
Copying paper	50 ml/min Bendtsen			●
Cardboard	Various grades	●	●	●



EcoSoft™ Delta: the new generation of soft calenders

It was to be expected that the positive experience with the Janus™ MK 2 would affect soft calender technology. The 45° design was included in the EcoSoft™ family of calenders in form of the EcoSoft™ Delta.

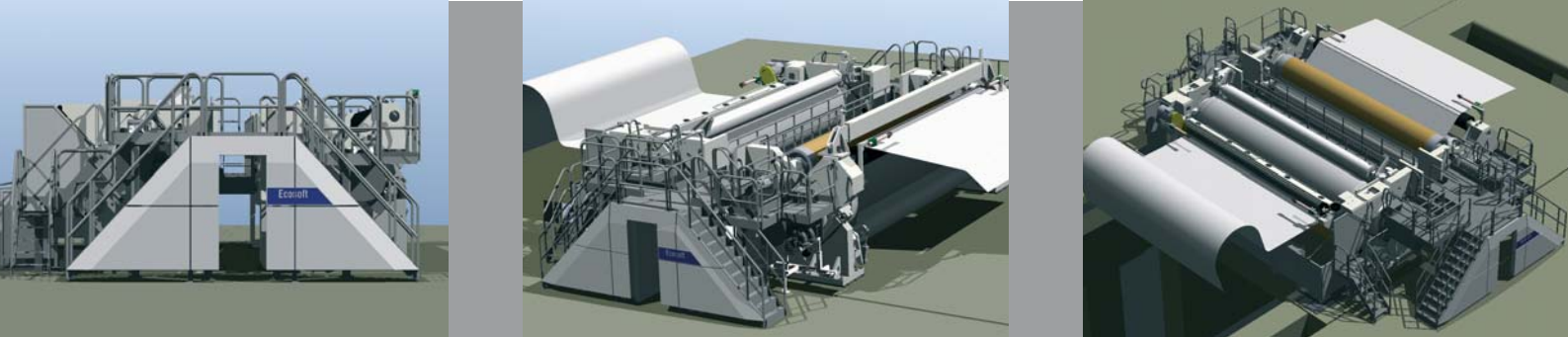

EcoSoft™ Delta calenders are planned down to the last detail in the CAD system prior to manufacture.

Experience with the Janus™ MK 2 showed that the 45° layout results in considerable advantages in the smooth running of the calender since the frames rest on a wider base. During the development of the Delta calender, value was placed on the natural vibration of the frame being well above the natural frequency of the rolls. This of course positively affects the smooth running of the calender and the service life of the rolls.

One of the main arguments in favor of the new EcoSoft™ Delta is the compact design of the calender and the much easier roll change.



*EcoSoft™ Delta with 2+2 rolls
for Shandong Huatai, China*

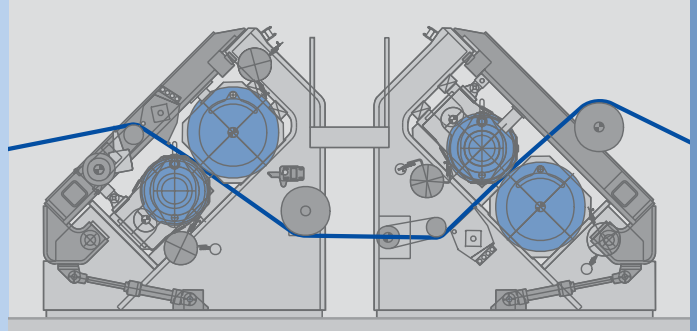

*EcoSoft™ Delta (2+2 rolls)
with DeltaLock™ system*

Another major advantage of the 45° layout is the fact that the roll bearings are always under load. Thus the risk of a "zero load" does not arise with this type of calender because a roll weight component is always acting positively on the bearings.

The high degree of user-friendliness of the EcoSoft™ Delta is a further point in its favor. The excellent accessibility for operation and maintenance which is already familiar from the Janus™ MK 2 has been adopted in the new layout. In addition, there is the integration of automation modules which facilitate optimum pre-assembly and thus shorter commissioning times.

The EcoSoft™ Delta calenders can be used for all web widths and operation speeds.

EcoSoft™ Delta: technology which makes many things easier for you



The EcoSoft™ Delta offers a number of convincing advantages. Due to its compact design it is not only the optimum for new installations but also for installation conversions with restricted space.

The compact design is a considerable advantage, particularly when integrating an EcoSoft™ Delta into existing production lines, because online installations place particular demands on roll change. This must be carried out quickly, easily and reliably. The 45° layout of the EcoSoft™ Delta makes roll change from above using the hall crane possible. There are a number of further advantages.

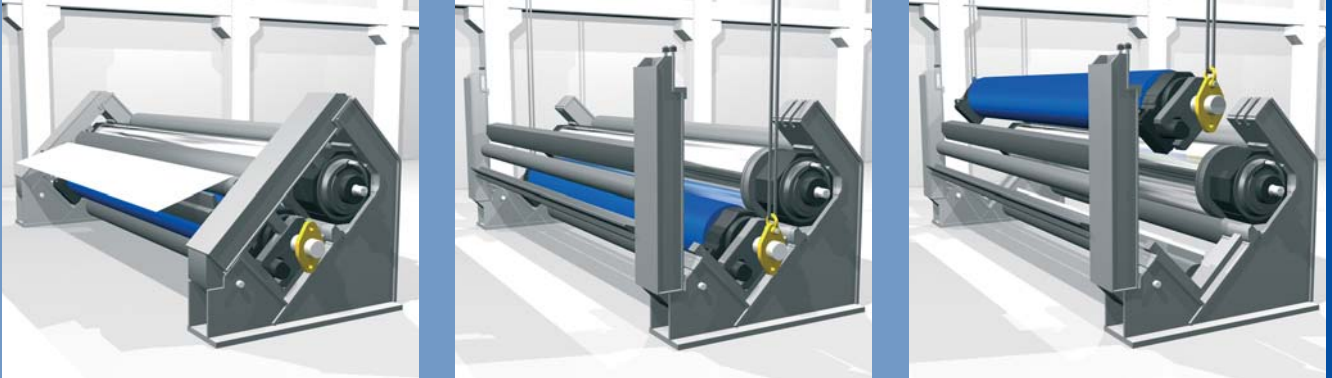

The DeltaLock™ system facilitates roll change, particularly with large working widths.

Innovative technology makes the difference: the DeltaLock™ system

The EcoSoft™ Delta is fitted with the newly developed DeltaLock™ system. This innovative element is an integral part of the frame and provides the basic pre-conditions for the rapid, reliable and easy roll change.

The DeltaLock™ system carries components such as the driven spreader roll, the severing blade and the steam blow box etc.. The system can be swiveled away completely for roll change without

the components and their drives including the supply lines having to be released. Thus all the rolls in the EcoSoft™ Delta can be accessed quickly and without problem with the hall crane.

When locked, the DeltaLock™ system causes a closed transmission force and positively affects the load distribution in the frame.

The advantages of the EcoSoft™ Delta at a glance

- Compact design
- High degree of smooth running
- Roll bearings always loaded
- Roll change is easy, fast and reliable
- Operating and maintenance friendly
- Good accessibility
- Concept proven in production

EcoSoft™ Modular: the modular calender kit for market-oriented installation solutions

The constant market success of the EcoSoft™ calenders and the experience gained from this led in the late 90s to the development of a calender kit which consistently covers the main application parameters in everyday production: the EcoSoft™ Modular.

The EcoSoft™ Modular is based on six frame sizes, optionally as 1-nip or 2-nip layout which means web widths of 1.350 infinitely variable up to a current 5.100 meters can be run. Standard elements are used for all machine sizes. The use of these standard components means that these installations can be implemented within a brief period with a technology which is profitable and has been proven in production.

Low operating costs, a high degree of operator friendliness with easily comprehensible maintenance as well as the compact design are the arguments which also make the EcoSoft™ Modular a very attractive alternative for conversions.



The standard components used are distinguished by their high reliability. They are based on over 20 years of experience with soft calender technology and the expertise amassed from the over 200 installations which have been delivered. EcoSoft™ Modular calenders offer all the functional basic elements which can today be expected of a soft calender. The combination of a heated roll with the tried and trusted Econip™ X roll leads to a nip with minimum line force deviations over the entire paper width.

Detailed CD-profile corrections are made possible by a version of the Nipcorect™ roll specially developed for the EcoSoft™ Modular; this roll also features compact roll bearings.



Every EcoSoft™ Modular is completely pre-assembled and tested at the shop.

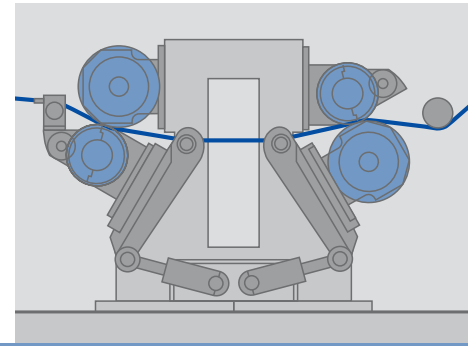

EcoSoft™ Modular calendars can be supplied as 1-nip variants or with 2 pairs of rolls.

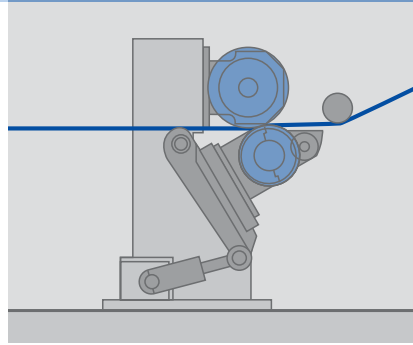

The concept planning of the EcoSoft™ Modular as a standard design kit included consideration of flexibility for specific customer requirements. Further additional components can be integrated without problem in the standard concept, such as for example a steam moistener, external CD profiling devices or threading systems. No wonder that the EcoSoft™ Modular is successfully in use for a variety of standard applications worldwide.

In the case of particular production specifications which exceed the conditions of the EcoSoft™ Modular calendar, EcoSoft™ L calendars may be used. These are so named due to their frame form and can be supplied as 2-roll or 2+2 roll calendars, in special cases also with several rolls in one stack. EcoSoft™ L calendars are, however, only used for particular specifications and production environments.

EcoSoft™ Modular: the most important arguments

- Fast set-up and commissioning
- Reliable technology
- Proven installation concept
- Excellent price performance ratio
- CD profiling with Nipcorect™ technology is possible

Voith roll technologies: innovation and experience for the highest productivity

Line load with Econip™ X roll

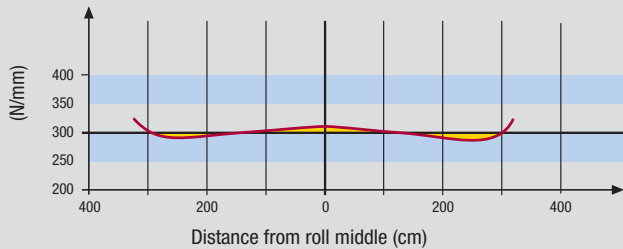

Line load with standard Econip™ roll

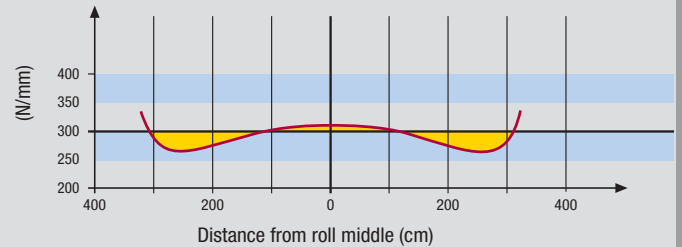

The Xtended version of the Econip™ roll means 65% less deviation in the line load.

The exact control of processes in the roll nip is decisive for the quality of the calendering process. An optimum CD profile over the entire width of the nip is one of the technological challenges in this. The various types of Voith deflection compensating rolls are used depending on specifications.

Voith rolls have confronted vastly differing applications with thousands of rolls delivered successfully; in addition to the paper industry, in the printing, plastics and fiber plate industries. The required CD-profiling ability is decisive for the selection of the roll type.

Econip™ rolls: the sure investment in proven roll technology

Econip™ rolls, in particular the Econip™ X with its optimized line load curve, provide proven roll technology for many standard installations. They offer a homogenous nip pressure over the entire width of the web and control even higher nip forces safely.

Hot and ready to go for the process: Flexitherm™ rolls

The Flexitherm™ heated rolls in the stack are chilled iron rolls with peripheral drill holes with the highest demands on surface properties as well as thermal and mechanical loading.

Highest surface temperatures are required for the online process with simultaneous high nip loads.

The much proven Duo-Pass technology of the Flexitherm™ rolls guarantees a homogenous temperature level over the entire paper width.

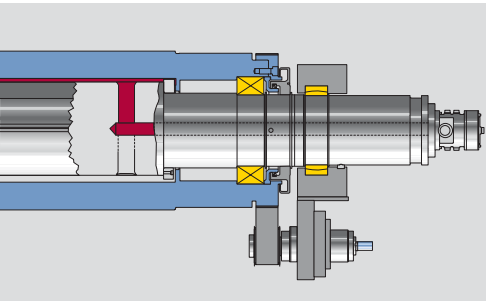

*Econip™ X roll with
extended bearings positions*

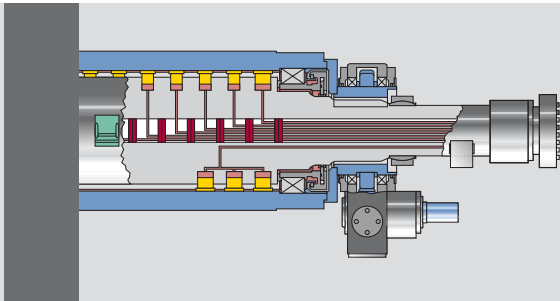

*Nipcorect™ roll with individually controllable
supporting elements*



*The axle of a Nipcorect™ roll
is inserted accurately
into the roll sleeve.*

**Nipco™ and Nipcorect™: great potential
for correction with decades of experience**

Nipco™ and Nipcorect™ rolls provide, in addition to the general line load compensation, the possibility of specifically correcting the CD profile of the web. In this process, 6 to 12 zones or even individual supporting elements can be controlled separately depending on the roll type in order to create the exact line load required in the nip.

**They remain unimpressed:
the new Vantis™ S roll covers**

Voith has launched decisive new developments in plastic covers on the market with a view to the constantly increasing demands made on the roll covers, particularly in surface quality and service life.

The new Vantis™ S covers were specifically developed for use in EcoSoft™ calenders to ensure an optimum in gloss and smoothness for as wide as possible a range of paper types. Vantis™ S covers are available in hardnesses of 88 to 92 Shore D. They have a very fine, homogenous surface, are particularly suitable for the use of blades and provide the best abrasion resistance and resistance to wear as well as being insensitive to marking and cracking.

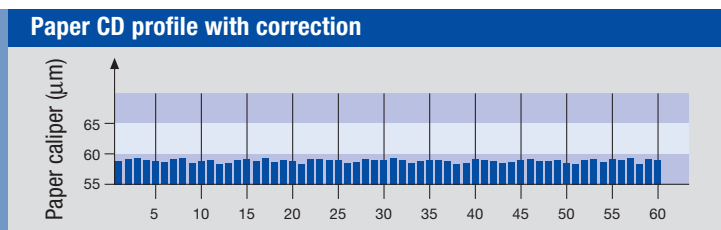
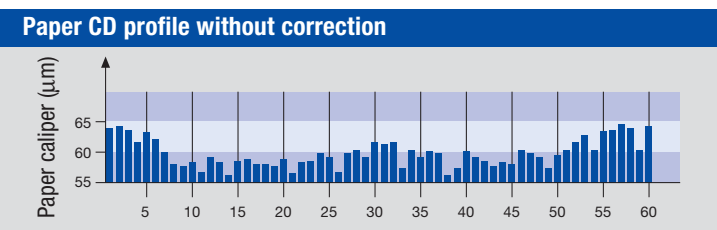

R&D at Voith: we develop today what you will need tomorrow

The increasing demands of everyday production, the close exchange with our customers and the comprehensive expertise gained from the many installations we have delivered mean that we are constantly redefining the limits of our technologies. Thus Voith always provides market-oriented and future-assured installation concepts.

Always reacting flexibly to the market, with a range of products which also takes future requirements into consideration; this requires the synergy of many years of experience from everyday production and the vision of our R&D specialists. Vastly differing calendering concepts and configurations can be tested under conditions similar to production in the Krefeld Finishing Technology Center to provide our customers with the guarantee for their investment.

The various installation configurations can be implemented on the test calenders in Krefeld. Thus, different EcoSoft™ operating modes and the novel NicoFlex™ wide nip calendering can be demonstrated on the 2+2 nip calender.



In addition to trials with customers' papers, new technologies are developed and tested in the Finishing Technology Center.

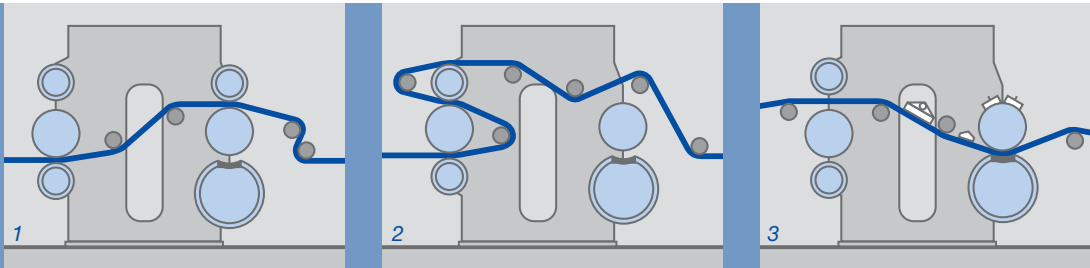

Different EcoSoft™ operating modes (1+2) and NipcoFlex™ operating mode with additional installations (3) on the Krefeld test calender

There is also a Janus™ MK 2 test calender available in the Technology Center. Thus, the entire range of Voith calendering concepts can be tested here. The calendered paper can subsequently be tested for all the relevant values in the affiliated paper test laboratory and the results documented in detail.

Technical data	Ecosoft™	NipcoFlex™
Speed	Up to 1,500 m/min	Up to 1,500 m/min
Number of nips	1 – 4	1
Shoe length	–	Up to 250 mm
Line load	Up to 500 N/mm	Up to 1,200 N/mm
Roll surface temperature	220 °C	250 °C
Heating	inductive	inductive and additional Calcoil
Additional extras	Steam moistener, water spray device and infrared preheating	
Paper roll width	640 mm	640 mm
Roll diameter	1,200 mm	1,200 mm
Core diameter	76 or 150 mm	76 or 150 mm



Janus™ MK 2 calender in Technology Center



Test calender for EcoSoft™ or NipcoFlex™ test series

Voith Paper GmbH
Postfach 10 21 54
47721 Krefeld
Birkschenweg 5
47803 Krefeld
Germany
Phone +49 2151 896 0
Fax + 49 2151 896 434

Voith Paper Limited
P.O. Box 8
Apex Works
Grimshaw Lane
Middleton
Manchester M24 1QT
England
Phone +44 161 643 9273
Fax +44 161 653 3114

Voith Paper Finishing Inc.
800 Worcester Street
P.O. Box 800
Springfield
MA 01101-0800
USA
Phone +1 413 726 1000
Fax +1 413 726 1010

VOITH
Engineered reliability.