

HyCon™ Digital turbine governor



Voith Hydro is a global leader in hydropower plant equipment and services for both new and modernization projects.

Our reputation for excellence in products and services is based on reliability, trust and commitment in long-lasting, partnering relationships with owners and operators around the globe.

This applies to overall plant engineering as well as to single component and system design in electrical and hydraulic machines, including the entire range of hydropower plant control concepts and systems. We offer hydro automation from a

single source to ensure complete service and seamless availability for your hydropower plant and all of its components and systems.

Our automation solutions are based on a variety of subsystems that ensure a safe, reliable and cost-effective operation through our long-term process know-how and control system expertise in hydropower applications.

From these systems, the turbine governor is central to control the hydro electric process. Our HyCon digital turbine governors offer perfect solutions for hydropower control.

At a glance

Today's technology meets long-term experience. Our tailor-made solutions help you to control the process. The proven control philosophy applied in HyCon turbine

governors has been successfully implemented in a vast number of hydropower plants of every type and size all over the world.

The ability to control a hydropower unit and the quality of the electric power it provides largely depends upon the performance of the turbine governing system. Voith Hydro is developing and manufacturing the core components of the turbine governor systems for more than 115 years. Today over 18.000 complete turbine governors were delivered and installed worldwide by Voith.

The HyCon digital governor is designed as an integral part of our HyCon Control System family. Our digital governors combine leading-edge technology with concepts that have proven their reliability and performance under all operating conditions over many years. By using the best hardware and software available it offers the highest availability. Because of its modular and flexible design, the governor can be customized to satisfy the requirements of every type of turbine. Our governors are designed to meet the high level of safety standards embedded in all Voith products. The HyCon digital governor has included all control modes required for any type of turbine.

Remarkable features of the HyCon digital turbine governor

- + All operation modes available
- + Meets and surpasses all relevant international standards
- + Advanced control concepts
- + Open communication standards
- + Parameter access and change without engineering tools
- + Independent local operation
- + Wide range of redundancy concepts
- + Hard- and software diagnosis in the PLC controller
- + Flexible remote access solutions

Main functions

The HyCon digital governors offer a wide extend of control modes to operate any kind of turbine in a safe and dynamic manner:

- Speed control
- Power control
- Water level control
- Flow control
- Pump control

Other features

- Excellent dynamic performance
- Flexible to stabilize pressure oscillations in complex water passages
- Primary and secondary control
- Quick step response
- Advanced stability for reference action of the control loop
- Advanced stability for disturbance action of the control loop
- Optimized interaction with our Thyricon excitation system

Furthermore, our extensive process know-how as a turbine manufacturer enables us to supply

- optimized functions for surge control
- individual servomotor control
- multi-needle control.

The system is designed for fully automatic operation. However, the operator can get detailed information about the status of turbine and governor via local and remote operator stations. This makes sure a safe and efficient operation and monitoring.

Limberg II, Austria



Governor control structure

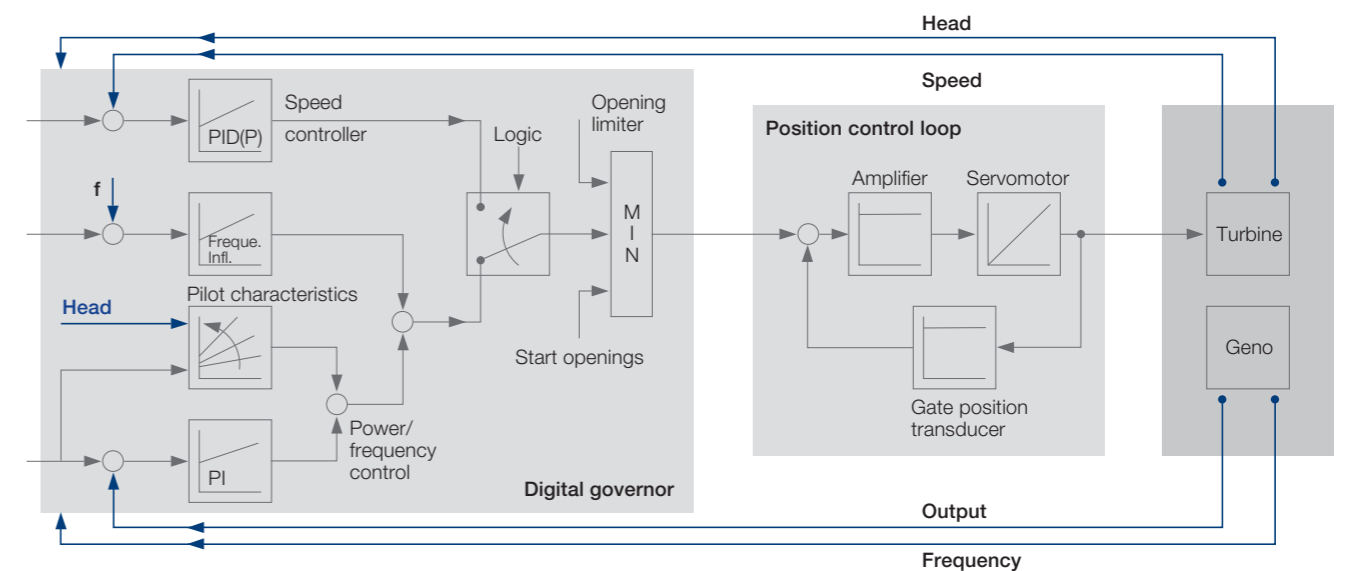

Hardware

The HyCon digital turbine governor is based on Siemens SIMATIC S7 components, which represent a globally accepted and well established industrial standard, characterized by

- Highest quality and reliability
- Worldwide availability of spare parts and support
- Proven technology applied in a wide range of industries with highly demanding requirements

Electric – Hydraulic Interface

The interface between the digital part of the turbine governor and the hydraulic part can be realized in several different ways. One Voith Hydro's own development is the so called VCA3 output amplifier card. This is a power amplifier for servo valves of the moving coil type with closed loop control for servomotor position. Additional current or voltage output for control of servo valves or proportional valves with integrated amplifier is provided. The VCA3 is providing performance features differentiating this solution from others like:

- Servomotor position control with both proportional and switchable derivate components
- Capable of changeover to manual set-point with built-in push buttons
- Opening limitations adjustable via analogue signal
- Current or voltage input for set-point
- Completely drift free
- Programmable interface and manual parameter/ set-point adjustments

Software

The HyCon digital turbine governor software is based on well known SIMATIC standards like Step7, CFC (Continuous Function Chart) and WinCC.

We offer:

- Modular and flexible systems
- Graphic user interface
- Easy and efficient parameterization
- Extensive diagnostic functions for fast and optimal maintenance.

Furthermore, the hydro specific functions of our HyCon governors allow for meeting various demands for different turbine types and specific operation modes of hydropower machines.

The HyCon digital turbine governor is designed as an integral part of our HyCon control system family making it more beneficial for operation, maintenance and spare parts management.

It is also compatible with third-party control systems due to its open and flexible interfaces and can be integrated into new as well as into existing hydropower plants.

Solutions for added value

HyCon digital turbine governors provide outstanding reliability, functionality and safety.

Flexible system

Due to its modular structure the system can easily be applied to both large and small hydropower plants. In addition, the concept flexibility of the HyCon governor fits well for both new plants and modernization projects. It is our mission to have a solution for any hydropower automation challenge.

Due to the extensive possibilities for parameterization, the digital turbine governor can be set up and adapted easily without having the need to do any kind of programming. This means flexibility and integrated safety by using well-tested components.

Redundancy concepts

As a result of perfect design and the use of highly reliable components, single systems without redundancy offer an extraordinary high level of reliability. In addition, we offer solutions to further increase the availability of the system. These scalable redundancy concepts fulfill all needs from redundant CPUs to redundant actors and sensors.

Independent local operation

As an added value, our HyCon turbine governor provides for independent local operation using an operator panel. This is helpful in special cases like commissioning, recommissioning after maintenance work or in emergency cases. All functionality to operate the system and detailed information about the status of turbine and governor is available at the panel.

Open communication

"Profibus DP used as the preferred solution of HyCon governors to communicate to decentralized IOs is the most widely used field bus system with more than 28 million installations worldwide. In addition a wide range of open interfaces including IEC 60870-5-101/103/104 and IEC 61850 is supported. Also widely used communication standards like ModBus or ProfiNet are supported by the HyCon Governor."

Hardware integration

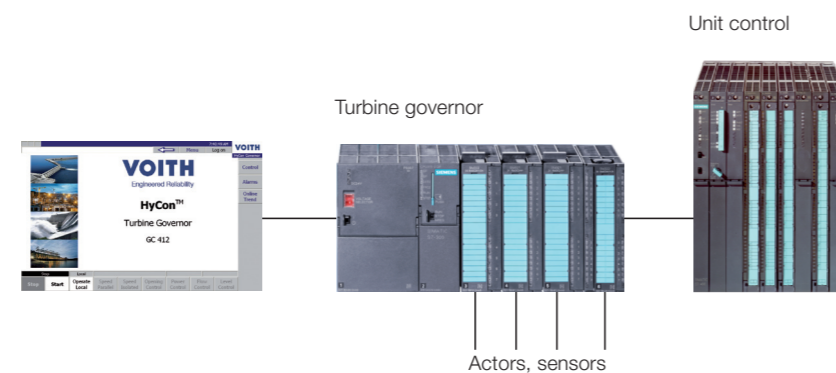

Independent local operation

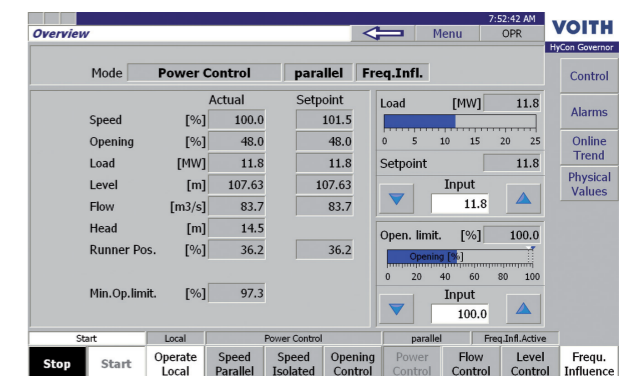

Components for an optimum control

Intelligent add-on modules implement our long-term process know-how to extend and optimize the usability of HyCon governors.

Real-time simulator

Due to its modular structure the HyCon turbine governor can be easily adapted to specific plant conditions based on a wealth of sophisticated and well-tested modules.

For critical water passages or complex closed-loop controlled systems, Voith Hydro offers a hardware-in-the-loop simulation based on SimsenRT that provides the simulation of a complete hydropower plant for testing the specific governor implementation under realistic conditions. This can be done even in the factory.

Simsen and its real-time variant SimsenRT, both developed at Ecole Polytechnique Fédérale de Lausanne (EPFL), are software packages for simulation of hydropower plants and electrical grids including all components.

Using this tool, specific plant conditions can be investigated in detail including optimization of existing functions and the testing of new control strategies.

Cam curve optimization

The basic data for the programmed gate-blade relationship, the so called cam curve, of Kaplan and bulb turbines contains unavoidable inaccuracies. This leads to more or less discrepancies in the unit and plant output compared to the optimum.

We offer a module to fully automatically optimize the cam curve that directly results in optimizing the profitability of the hydropower plant.

Safety

Our turbine governor is designed to meet the high level of safety standards embedded in all Voith products to ensure an optimum of safety for the user, the equipment and the environment.

An alarm system provides detailed information for the operator. The clear representation of this data allows fast and efficient tracking of any faults.

Hydraulic mechanical governor components

Optimally aligned hydraulic mechanical governor components help the digital turbine governor to play its strength. To add matching actuators to the digital governor, we design and deliver:

- Electro-hydraulic amplifiers
- Control valves
- Precisely positioning servomotors

Voith delivers all components for further hydraulic control systems like:

- Ring gate controls
- Butterfly valve controls
- Spherical valve controls
- Sleeve valve controls
- Gate controls for intake and draft tube
- Torque converter controls
- Pressure relief valve controls

Real-time simulator

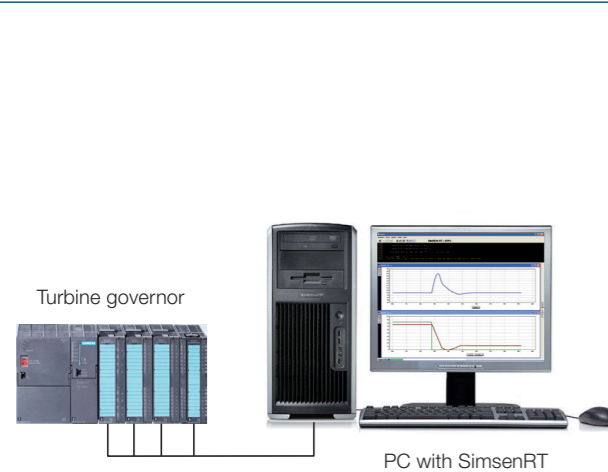

Model of Power Unit within simulation

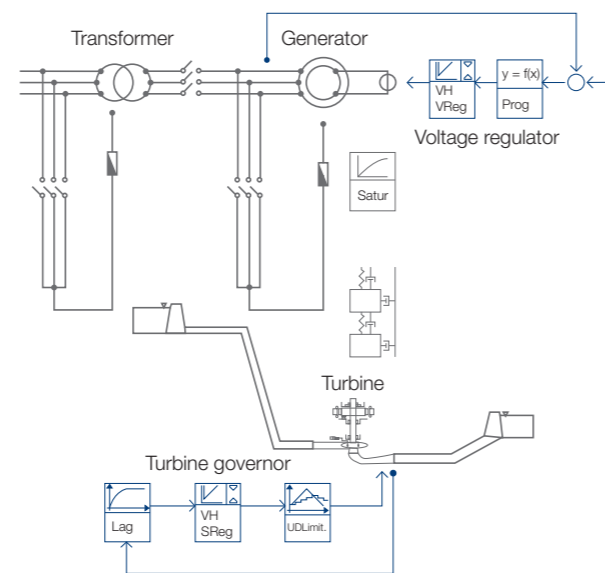

1 Test rig for individual gate control

2 Hydraulic mechanical components

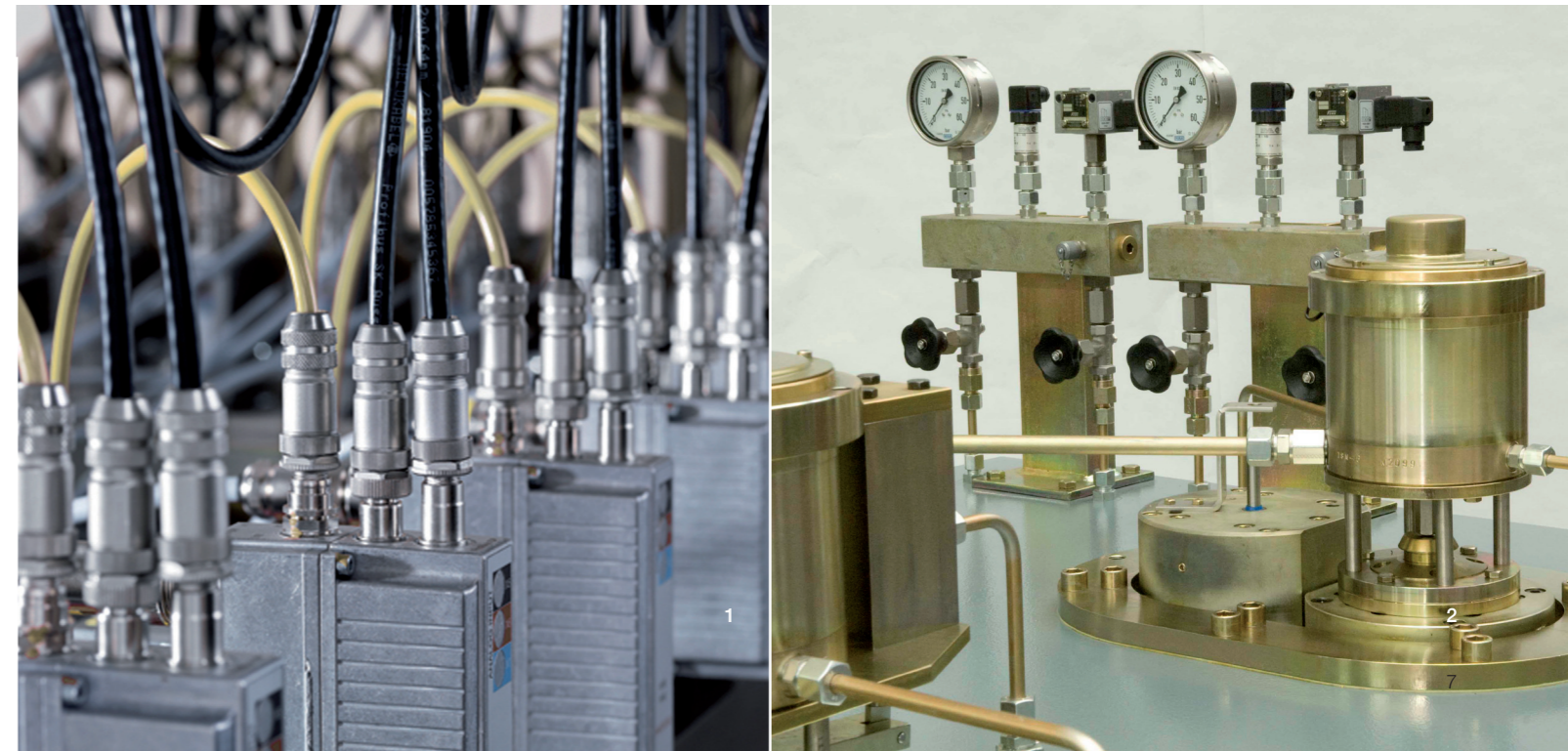



1 Estreito, Brazil

2 Akköy II, Turkey

- 1891** First mechanical governor
- 1998** Guangzhou II, China:
4 x 350 MW Pump turbines
- 2003** Gibel Gibe II, Africa:
4 x 125 MW Pelton turbines
- 2004** Foyers, Scotland:
2 x 150 MW Pump turbines
- 2006** Rheinfelden, Switzerland:
4 x 25 MW Bulb turbines
- 2006** Limberg II, Austria:
2 x 240 MW Pump turbines
- 2007** Estreito, Brazil:
8 x 135 MW Kaplan turbines
- 2008** Akköy II, Turkey:
2 x 117 MW Pelton turbines

- 2010** Salto Pilao, Brazil
2 x 93 MW Francis turbines
- 2011** Budarhals, Iceland:
2 x 40 MW Kaplan turbines
- 2011** Frades II, Portugal:
2 x 380 MW variable speed pump turbine
- 2011** KARGI, Turkey:
2 x 52 MW Francis turbines
- 2011** Rongnichu, India:
2 x 48 MW Pelton turbines
- 2012** Alfalfal II, Chile:
2 x 140 MW Pelton turbines
- 2012** Cambambe 2, Angola:
4 x 175 MW Francis turbines
- 2012** Las Lajas, Chile:
2 x 142 MW Pelton turbines

Voith Hydro Holding GmbH & Co. KG
 Alexanderstraße 11
 89522 Heidenheim, Germany
 Tel. +49 7321 37 0
 Fax +49 7321 37 7828

www.voith.com

A Voith and Siemens Company

VOITH
 Engineered Reliability