

Kaplan turbines





1

Cover picture Estreito, Brazil



2



3

- 1 Uglichskaya, Russia
- 2 Embretsfoss IV, Norway
- 3 Wanapum, USA

Harnessing the power of water with engineered reliability

Generating electricity from the power of water represents large amounts of clean, renewable energy. 71 percent of the earth's surface is covered by water. The world's hydropower potential amounts to 20 billion Megawatt hours per year and only 25 percent of this has been developed so far.

Hydropower is not only environmentally friendly, but also cost-effective. Hydro-power plants have the highest operating efficiency of all renewable generation systems. They are largely automated, and their operating costs are relatively low. Hydroelectric power plants also play an important role in water resource management, flood control, navigation, irrigation and in creating recreation areas.

Voith is an industry leader in the production of generators, turbines and the associated control systems to put the power of water to work. A range of services, from engineering through manufacturing and project management to commissioning, completes our portfolio as one of the world's leading hydro-power product and service provider.

As part of our international network each Voith facility is equipped with consistent best-in-class processes and tools. This network also ensures that we can meet special customized requirements: from individual components to project planning, through project management and plant maintenance. With branches and production facilities for electrical and hydraulic machines and

components in Europe, Asia, North and South America we are close to our customers and active in all major hydro-power markets worldwide.

With more than 140 years experience in the field of hydropower and major achievements in research and development, Voith is well equipped to continue delivering excellence in hydropower in the years to come.

Engineered reliability

Is our promise to our customers. Our products and services are designed specifically for our customers' needs. Always efficient and economical and, above all, following our values and visions for sustainable hydro power solutions.

Competence and capabilities

- Consulting, engineering, erection and commissioning
- System/plant assessments
- HyService – global, fast and effective for modernization and rehabilitation of existing hydroelectric power plants
- Complete equipment, installation and services for hydroelectric power plants
- Francis, Pelton, Kaplan, Bulb/Pit/S-turbines, pump-turbines, standard and customized products
- Storage pumps, radial, semi-axial and axial-flow pumps
- Generators and motor-generators for constant and adjustable speed, excitation systems
- Frequency converters, protection systems, switchyards for all voltages, transformers
- Power plant automation, control centers for hydro power plants and cascades, including plant management and diagnostic systems
- Shut-off valves
- Integrated Management System to safeguard excellence and quality

Characteristics

From the beginning, Kaplan turbine development has always been synonymous with Voith.

In 1913, the company was the first to recognize the importance of Victor Kaplan's invention and, in partnership with him, developmental tests were performed in the Voith research laboratory. Since then, thousands of Kaplan turbines have left our manufacturing facilities, among them the world's largest and most powerful.

Our program offers an economical solution for any requirement. Large custom-built Kaplan turbines for high output ranges are Voith's speciality.

Custom Kaplan turbines are used primarily for lower heads and larger flows.

Voith also supplies cost-effective Kaplan units in standardized designs for smaller hydropower plants.

Application range Kaplan turbines

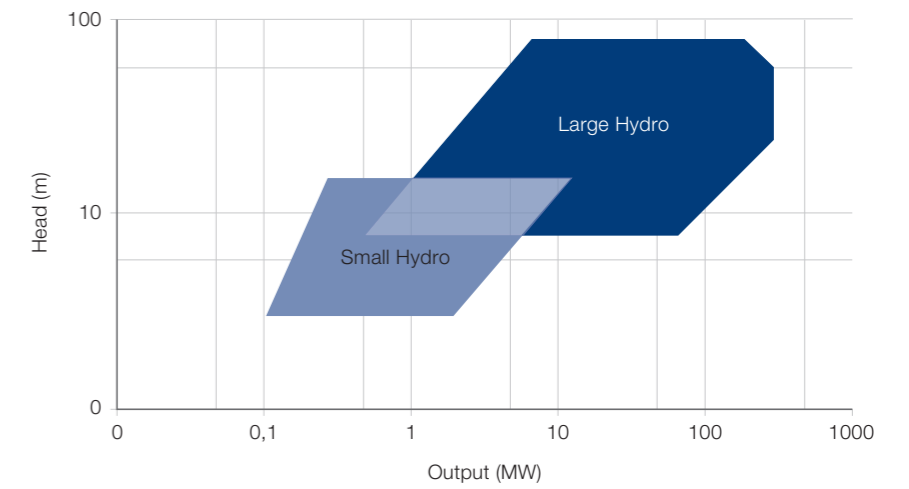

Modern Layout for Large Kaplan Machine

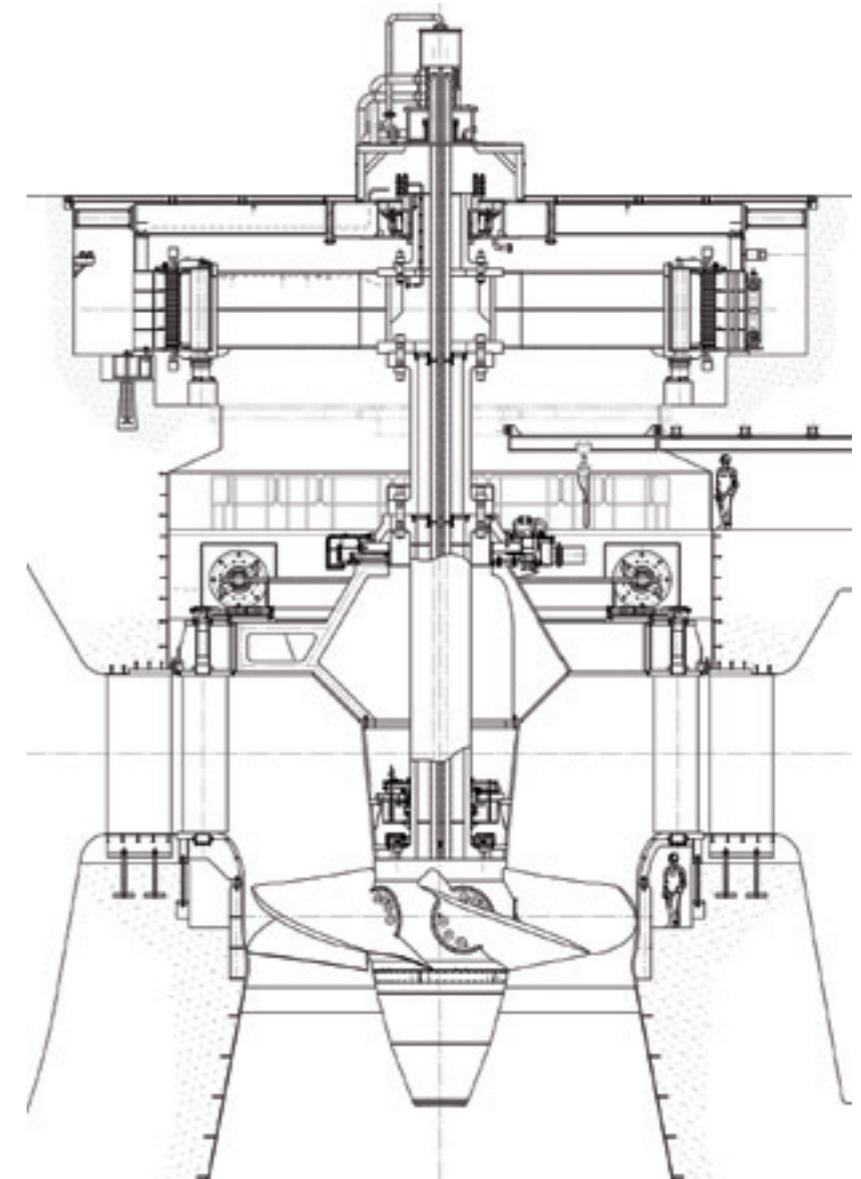

- 1 Aimores, Brazil
- 2 Workshop, St. Pölten, Austria





1 PeixeAngical, Brazil
 2 Budarhals, Iceland
 3 Yacyreta, Argentina
 4 Lajeado, Brazil

1870 Hydro turbine manufacture began.

1916 Development of Voith Kaplan model turbine.

1922 First prototype Kaplan turbine, Austria.

1928 Ryburg-Schwörstadt, Germany:
 Most powerful and largest Kaplan turbines of their time with an output of 35 MW and a runner diameter of 7 m.

1952 Jochenstein, Germany/Austria:
 Runner diameter 7.4 m.

1958 Três Marias, Brazil:
 Kaplan turbines under a head of 50 m with 8 runner blades.

1960 Aschach, Austria:
 Runner diameter 8.4 m.

1964 St. Martin, Austria:
 Kaplan turbines under a head of 75 m with 7 runner blades.

1973 Toyomi No. 2, Japan:
 Kaplan turbine with an output of 61 MW at a head of 24.5 m.

1978 San Lorenzo, El Salvador:
 2 x 92.4 MW Kaplan turbines with an operating head of 30 m.

1979 Nova Avanhandava, Brazil:
 Kaplan turbines with an output of 112 MW.

1980 Taquarucu, Brazil:
 5 x 103 MW Kaplan turbines at a head of 21.9 m.

1981 Aswan II, Egypt:
 4 x 67.6 MW Kaplan turbines with an operating head of 20.1 m.

1988 Yacyretá, Argentina:
 The largest and most powerful Kaplan turbines in the western world rated at 154 MW with a runner diameter of 9.5 m.

1995 Rocky Reach, USA:
 Most advanced fish-friendly designed Kaplan turbine in the industry.

1999 Aimores, Brazil:
 3 x 112.3 MW Kaplan turbines at a head of 25.8 m with a runner diameter of 8.47 m.

2001 Ping Ban, China:
 3 x 138 MW Kaplan turbines at a head of 34 m.

2002 Lajeado, Brazil:
 Kaplan turbine with an output of 183.5 MW at a head of 34 m.

2002 Peixe Angical, Brazil:
 3 x 168.8 MW Kaplan turbines at a head of 24.3 m with a runner diameter of 8.6 m.

2005 Cao Jie, China:
 4 x 128 MW Kaplan turbines at a head of 20 m with a runner diameter of 9.5 m.

2006 Holtwood Expansion, USA:
 2 x 59.2 MW Kaplan turbines at a head of 15.5 m.

2007 Uglichskaya, Russia:
 Kaplan turbine with an output of 70 MW with a runner diameter of 9 m.

2007 Estreito, Brazil:
 8 x 138.7 MW Kaplan turbines at a head of 18.94 m with a runner diameter of 9.5 m.

2008 Akkats, Sweden:
 Two new 75 MW-turbines with 5 blade design under a maximum head of 46 m.

2008 Cheonpyeong Ext., South Korea:
 Kaplan turbine with an output of 60 MW at a head of 22.3 m.

2010 Ferreira Gomez, Brazil:
 3 x 86.5 MW Kaplan turbines at a head of 16.2 m.

2010 Embretsfoss IV, Norway:
 Kaplan turbine with an output of 49.5 MW at a head of 16 m.

2011 Budarhals, Iceland:
 2 x 40.1 MW Kaplan turbines at a head of 36.2 m.

2011/2012 Saratovskaya, Russia:
 Modernization and uprating of 9 Kaplan turbines with an output of 68 MW with a runner diameter of 10.3 m.

Voith Hydro Holding GmbH & Co. KG
Alexanderstraße 11
89522 Heidenheim, Germany
Tel. +49 7321 37 0
Fax +49 7321 37 7828
www.voith.com

A Voith and Siemens Company

VOITH
Engineered Reliability