

Proven a Million Times. Fluid Couplings with Constant Fill



Foettinger's concept – Design and function

The Voith fluid coupling is a hydrodynamic coupling based on Foettinger's Principle. Its main components are two bladed wheels – a pump wheel and a turbine wheel – as well as an outer shell. Both wheels are positioned relative to each other. Power transmission is achieved with minimal mechanical wear and there is no mechanical contact between the power-transmitting components.



Principle of hydrodynamic power transmission

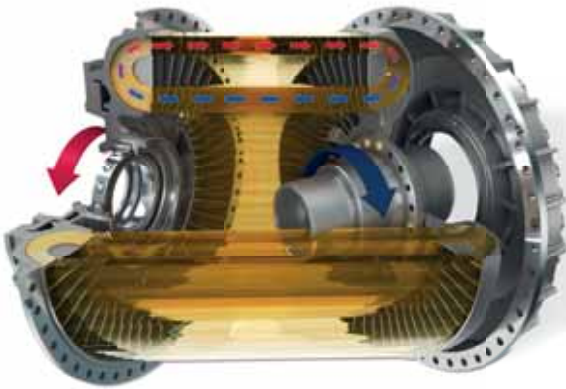

The coupling operates on a constant quantity of operating fluid, usually mineral oil. On demand, design for water is available. The torque transmitted by the drive motor is converted into kinetic energy of the operating fluid in the pump wheel to which the motor is connected. In the turbine wheel, this kinetic energy is converted back into mechanical energy. Three operating modes are defined:

Standstill

The entire operating fluid in the coupling is at rest.

Start-up

With increasing speed, the operating fluid in the working circuit is accelerated via the pump wheel. The circulatory flow created in this way is supported by the turbine wheel and sets the latter in motion. The torque development is determined by the characteristic curve of the coupling, while the start-up characteristics are influenced by an appropriate arrangement of compensating chambers (delay chamber, annular chamber).

Nominal operation

The low speed difference between pump and turbine wheel (the so-called nominal slip) leads to the flow condition in the coupling becoming stationary. Only the torque required by the driven machine is transmitted.

Standstill

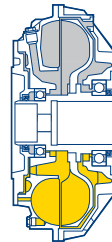

Start-up

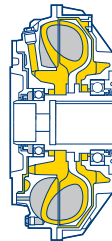

Nominal operation

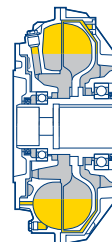

Voith Fluid Couplings – proven a million times

As an expert for difficult tasks in power transmission Voith meets the steadily increasing requirements in practice and convinces through innovative performance. Constant-fill Voith fluid couplings (turbo couplings) are used with electric motors in a wide range of applications, especially when highest powers, economy and reliability are required.

- 1 Bucket wheel excavator in open-pit lignite mine, Czech Republic
- 2 Belt conveyor and stacker/reclaimer in coal terminal, South Africa
- 3 Armored face conveyor in underground coal mine, China
- 4 Belt conveyor with TVS coupling in open-pit copper mine, Chile
- 5 Belt conveyor with TVS coupling in underground potash mine, Germany

The Voith fluid coupling with its inherent hydrodynamic advantages has proved itself by millions of sales worldwide:

- Smoothest acceleration of the largest masses
- Suitable for economically priced squirrel cage motors
- Load free start-up and run-up of the motor
- No motor modification required
- Torque limitation during start-up
- Effective shock-dampening
- Overload protection for motor and driven machine
- Load compensation for multi-motor drives



Applications

Material handling and conveying

- Belt conveyors
- Bucket wheel elevators
- Chain conveyors
- Stackers and reclaimers
- Port loading facilities

Mineral processing machines

- Crushers
- Shredders
- Mills

Mining: Open-pit and underground

- Armoured face conveyors
- Stage loaders
- Belt conveyors
- Tunnelling machines
- Bucket wheel excavators
- Pumps
- Crushers
- Mills

Chemical industry

- Centrifuges
- Pumps
- Fans
- Mixers

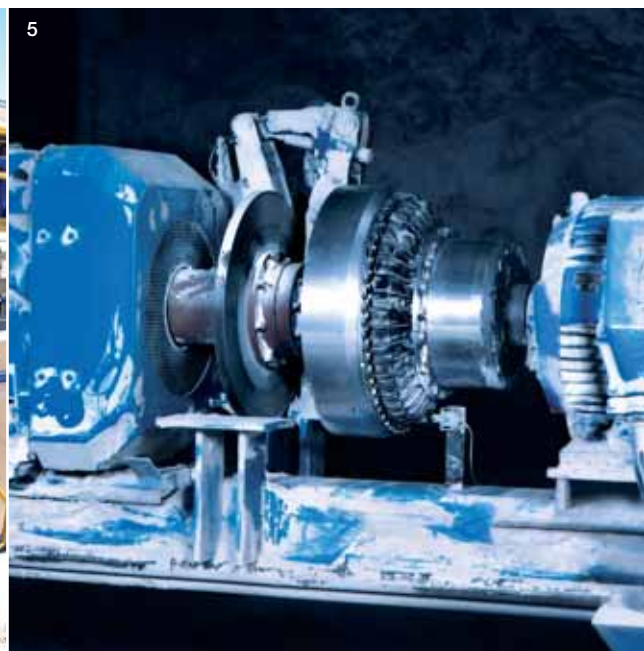

4

5

A suitable coupling for any drive

Essential design factors for a fluid coupling are the power and motor speed. Having established the nominal power and speed required, the diagram on the right enables determination of the appropriate size of the coupling.

Different conditions require different starting procedures (characteristic curve) for the coupling. Important criteria in this respect are the mass moment of inertia, torque limitation and frequency of start-ups.

Performance diagram

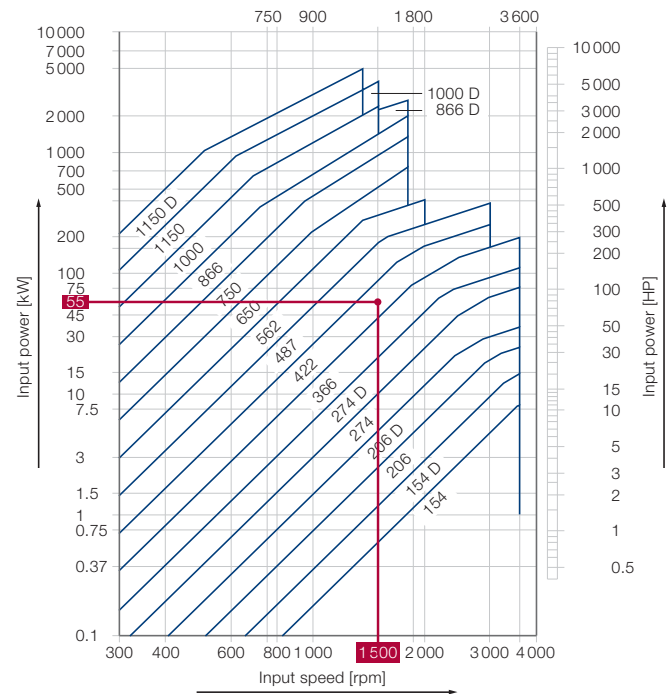

Example: ■
 Rated power: 55 kW
 Input speed: 1500 rpm
 Coupling size: 422

Characteristic curves

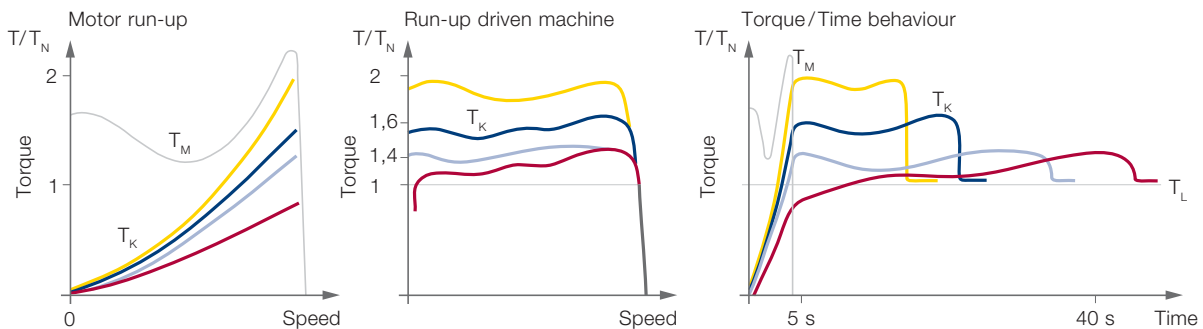

In the table beside different types of couplings' starting behaviour can be compared.

- Type T
 - Type TV
 - Type TVV
 - Type TVVS
- T_M : Motor torque
 - T_L : Load torque
 - T_K : Coupling torque
 - T_N : Rated torque
 - J: Moment of inertia
 - T_L : Const.
 - J: Const.

The basic type – Fluid coupling type T and DT

Fluid coupling type T is the basic version of constant-fill couplings, consisting of pump wheel, turbine wheel and outer shell. A further range has been created by the addition of other parts to this basic type.

The fluid coupling is normally mounted on the machine shaft or gearbox shaft to be driven (outer wheel drive). In order to compensate for any slight installation inaccuracies, a flexible connecting coupling is used to join the coupling and input shaft. Use of this type of fluid coupling is recommended when vibration damping and overload protection are required for motor and driven machine; they may also be used for simpler transmission systems in the lower performance range. The coupling type DT has two coaxial work circuits operating in parallel. By means of a double circuit the output of the same size coupling is effectively doubled.

Applications

- Bucket-wheel excavators
- Bucket-wheel elevators
- Mixing, kneading and stirring machines

Dimensions

Size	Types	A	D	L	d ₁ max.	d ₂ max.	l ₁ max.	Weight ¹⁾
				[mm]				[kg]
154	T	80	190	143	32	28	60	4
154	DT	102	190	165	32	28	80	5
206	T	97	248	183	42	42	80	10
206	DT	137	248	223	42	42	114	13,4
274	T	135	328	202	70	55	90	27
274	DT	175	328	242	70	55	125	32
366	T	198	424	276	90	65	120	44
422	T	218	470	320	100	80	135	68
487	T	246	556	352	120	90	155	102
562	T	269	634	385	130	110	170	146
650	T	317	740	469	140	120	200	240
750	T	366	846	529	150	135	240	358
866	T	421	978	610	160	150	265	573
1000	T	441	1118	651	180	160	280	850
1150	T	505	1295	715	180	180	320	1110
1150	DT	830	1295	1040	180	180	350	1806

¹⁾ Weight with connecting coupling and max. oil filling.

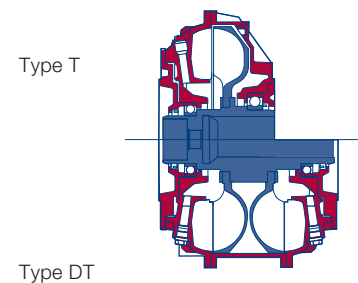
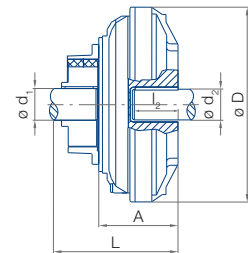

Smoother start up – Fluid coupling type TV and TVV

The TV version features a “delay-fill chamber” which is flange-connected to the outer wheel of the coupling. At stand-still, a proportion of the working fluid lies in this chamber, thus reducing the volume in the working circuit.

Hence on motor start-up, a reduced coupling torque is transmitted, whilst simultaneously providing an unloaded motor start. After the motor has run up, the working fluid flows from the delay-fill chamber into the working circuit which smoothly accelerates the driven machine up to its operating speed. Furthermore, if the application so demands, the delay-fill chamber can be further enlarged (type TVV), thus enhancing its effects and further reducing the coupling torque on motor start, as

well as resulting in even longer and smoother start-up of the driven machine. In certain cases, the function of the delay chamber can be additionally improved through centrifugally controlled valves (type TVF) or through hydrodynamic refill (type TVY).

Applications

- Belt conveyors
- Centrifuges, decaners
- Tube mills
- High-inertia machines
- Crushers

Dimensions

Size	Types	A	D	L	d ₁ max.	d ₂ max.	l ₁ max.	Weight ¹⁾
				[mm]				[kg]
274	TV	172	328	239	70	55	125	30
274	TVV	204	328	260	42	55	90	28
274	DTV	244	328	300	42	55	125	34
366	TV	225	424	303	90	65	120	46
366	TVV	296	424	374	90	65	120	49
422	TV	257	470	359	100	80	135	71
422	TVV	335	470	437	100	80	135	75
487	TV	297	556	403	120	90	155	106
487	TVV	382	556	488	120	90	155	114
562	TV	333	634	449	130	110	170	153
562	TVV	428	634	544	130	110	170	162
650	TV	384	740	536	140	120	200	249
650	TVV	494	740	646	140	120	200	264
750	TV	440	846	603	150	135	240	373
750	TVV	567	846	730	150	135	240	393
866	TV	493	978	682	160	150	265	575
866	TVV	641	978	830	160	150	265	609
1000	TV	547	1118	757	180	160	280	875
1000	TVV	686	1118	896	180	160	280	919
1150	TV	670	1295	880	180	180	320	1219
1150	TVV	883	1295	1093	180	180	320	1310
1150	DTV	1208	1295	1418	180	180	350	1996

¹⁾ Weight with connecting coupling and max. oil filling.

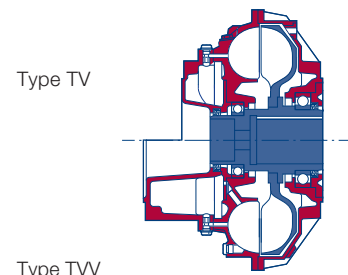
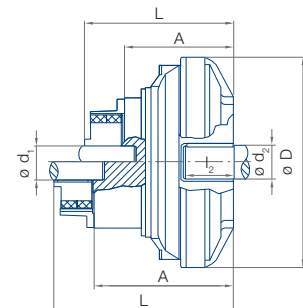

The innovative one – Fluid coupling type TVVS

The TVVS is a further Voith development in cooperating an annular-chamber shell in addition to the enlarged delay chamber. The additional chamber in the coupling shell enables further reduction of the starting torque. During the initial rotations of the start-up procedure, centrifugal forces normally cause the outer chamber of the coupling to be completely filled with operating fluid from the working circuit.

In comparison with couplings without annular chamber, filling of the working circuit of a TVVS coupling is considerably reduced, which, in turn, lessens the torque transmitted during

motor run-up. The increase in torque then follows a gradual emptying of the fluid from the delay chamber into the working circuit. The starting procedure can be adapted to the requirements of the application by adjustable nozzle screws diameters. This new concept for couplings was designed originally for conveyor belt drives. Through the gradual build up of torque an automatic adaptation to belt load conditions is achieved.

Applications

- Belt conveyors
- High-inertia machines

Dimensions

Size	Types	A	D	L	d ₁ max.	d ₂ max.	l ₁ max.	Weight ¹⁾
				[mm]				[kg]
422	TVVS	335	470	437	100	80	135	83
487	TVVS	382	556	488	120	90	155	128
562	TVVS	428	660	544	130	110	170	185
650	TVVS	494	761	646	140	120	200	301
750	TVVS	567	877	730	150	135	240	454
866	TVVS	641	1017	830	160	150	265	696
1000	TVVS	686	1165	896	180	160	280	1010
1150	TVVS	883	1340	1093	180	180	320	1478

¹⁾ Weight with connecting coupling and max. oil filling.

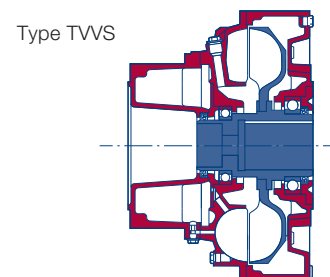
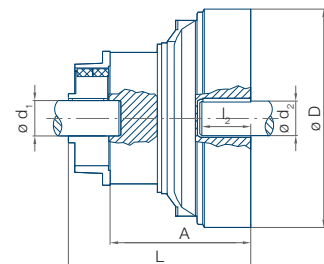

For pulley drives – Fluid coupling type TRI and TVRI

The V-belt or flat belt pulley which is mounted to the bearing cover allows various transmission ratios to be accommodated. If required, the pulley may be easily changed.

TRI and TVRI type fluid couplings are normally installed on the motor shaft in an overhung position. The belt force is supported by a bearing in the bearing cover on the coupling hub.

TRI couplings can be installed both as start-up device and overload protection. Type TVRI with additional delay chamber is recommended if a particularly smooth start-up is required.

Applications

- Centrifuges, decaners
- Fans
- Mixers
- Crushers

Dimensions

Size	Types	A	D	B max. [mm]	d ₁ max.	d max.	Weight ¹⁾ [kg]
206	TRI	97	248	70	116	42	9
206	DTRI	137	248	70	116	42	12
274	TRI	137	328	100	150	55	25
274	TVRI	172	328	100	150	55	26
274	DTRI	175	328	135	165	60	33
274	DTVRI	242	328	135	165	60	38
366	TRI	198	424	145	160	65	47
366	TVRI	225	424	145	160	65	51
422	TRI	205	470	160	182	70	74
422	TVRI	258	470	160	182	70	76
487	TRI	246	556	201	233	90	110
487	TVRI	297	556	201	233	90	112
562	TRI	269	634	294	265	100	173
562	TVRI	333	634	294	265	100	175
650	TRI	317	740	272	423	105	256
650	TVRI	384	740	272	423	105	261

¹⁾ Weight with connecting coupling and max. oil filling.

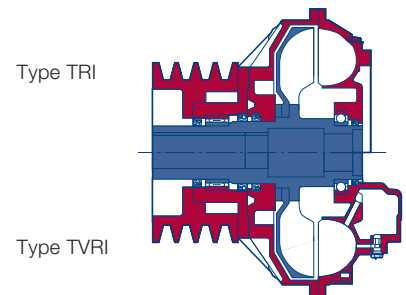
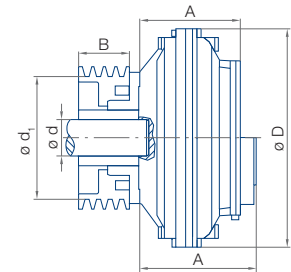

Monitoring devices and accessories

MTS – Mechanical thermal switch

As protection against overheating, fusible plugs are a standard feature. In order to avoid loss of operating fluid through thermal overload, a mechanical thermal switch (MTS) can be added. On achieving the response temperature, the element activates a pin which then operates a switch. Depending on the type of circuit, the signal can be used either as an alarm or to switch off the motor. The circuit element has to be replaced after activation.

For inner wheel drives, we recommend the BTS non-contact thermal switch.

BTS – Non-contact thermal switch

Monitoring of coupling temperatures takes place without any contact. After activation of the switch, no replacement of the element is required. It is ready for use as soon as the coupling has cooled down. The signal can be used either as an alarm or to switch off the motor.

Mounting and removal device

Required for professional, safe installation and removal. As well as the mechanical tool, a hydraulic removal tool is available.

Sight glass

By fitting a sight glass, the fluid level in the coupling can be easily checked without opening the coupling.

BTM – Innovative technology for process optimization

The newly developed temperature monitoring system for fluid couplings “BTM”, allows increased process optimization. Continuous sensing of the actual temperature of the operating fluid in the Voith Turbo fluid coupling represents a new capability and offers two decisive benefits: The thermal reserves of the coupling can be better utilized and intervention in the process to achieve specific objectives is more readily accomplished.

- 1 MTS – Mechanical thermal switch.
- 2 BTS – Non-contact thermal switch.
- 3 Mounting and removal device.
- 4 Sight glass.
- 5 BTM – Innovative technology for process optimization.

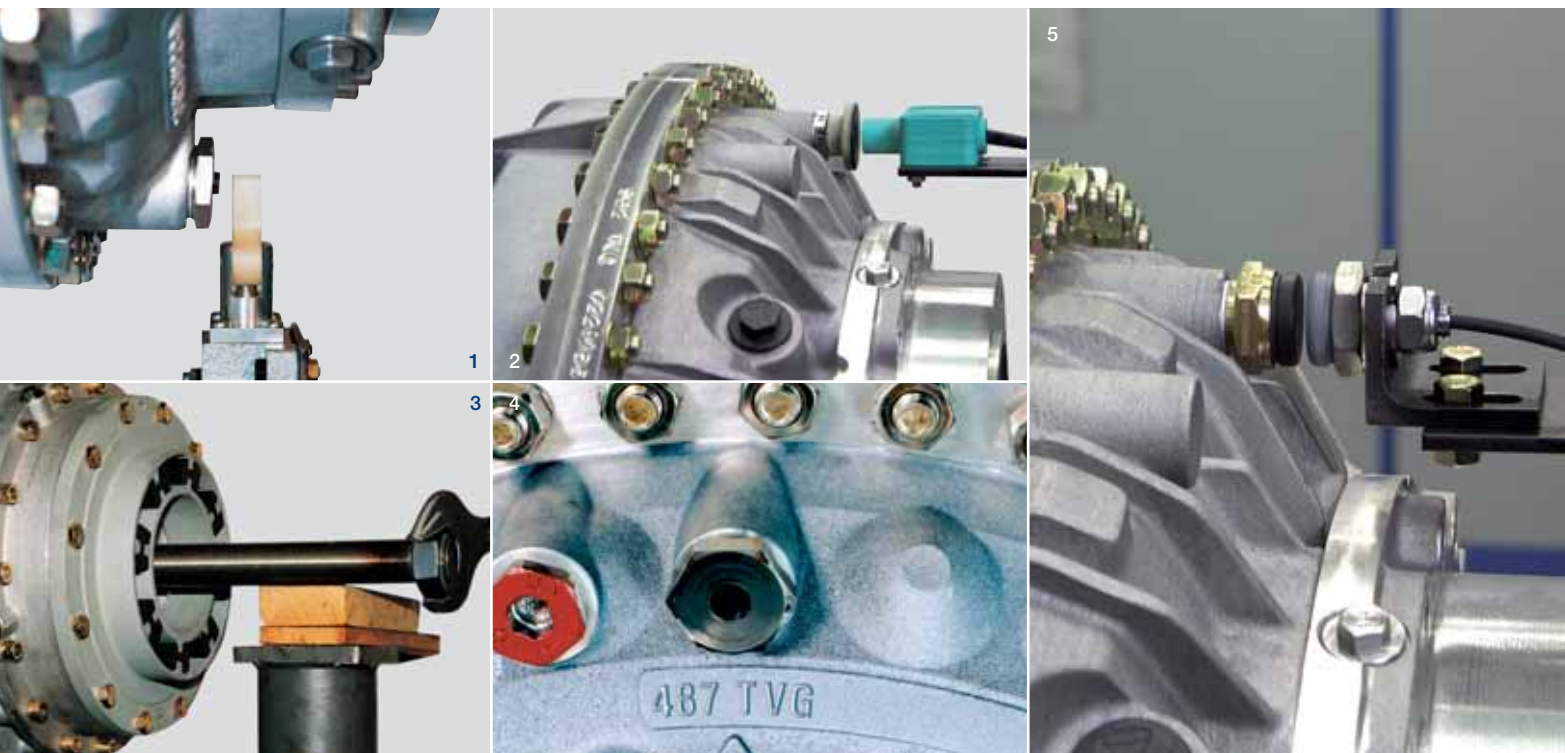

For special applications – Additional types

In order to provide solutions for an ever greater variety of applications, our engineers and technicians have developed additional types of constant-fill couplings.

1 Fluid coupling with multi-disc coupling (GPK)

The design of motor and drive unit is becoming more and more compact without affecting the actual performance of the drive. This consequently leads to smaller diameters of motor and gearbox shafts which then suffer from reduced load capacity. For such cases the weight of the fluid coupling is distributed to both the driving and the driven shaft via two disc-pack couplings. The reduced load on shaft and bearings contributes significantly to an extended service life of bearings. It is also possible to remove the fluid coupling radially, without dismantling the motor and gearbox.

2 Fluid coupling with solid shaft and primary coupling flange

The coupling is fitted rigid to the motor shaft over a primary coupling flange. The weight of the coupling is thus carried by the motor shaft and the load on the driven shaft is relieved. The flexible connecting coupling is fitted between the solid output shaft and the gearbox, on drives with braking systems the brake disc/drum is fitted to the flexible coupling.

3 Fluid coupling with brake flange

For use with a braking system, the fluid coupling can be equipped with an additional brake flange to which a brake-drum or brake-disc can be mounted.

4 Pulley-type coupling without bearing cover – Type TRI/TVRI

This type is ideally suited for particularly small pulley diameters. The pulley with integral bearing is flanged directly to the coupling shell. Replacement of the belt pulley is suggested to be done at the Voith factory.

5 Fluid coupling with overhung pulley installation – Type TR

In this simplified version of the pulley coupling, the pulley is fitted to the coupling shell in an unsupported version. Fluid coupling type TR is an economical solution for applications in the lower power range.

6 Fluid coupling with water as operating medium – Type TW

Voith Fluid coupling – designed for operating fluid water – can be used in such cases, where mineral oil is restricted of safety and ecological reasons. Especially in underground coal mining the water type couplings are preferred. Higher power transmissions on account of this medium is also given.

Additional types

1

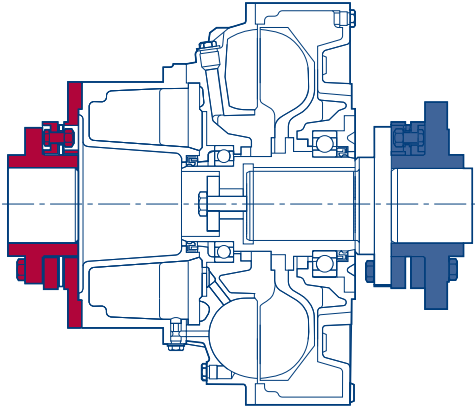

2

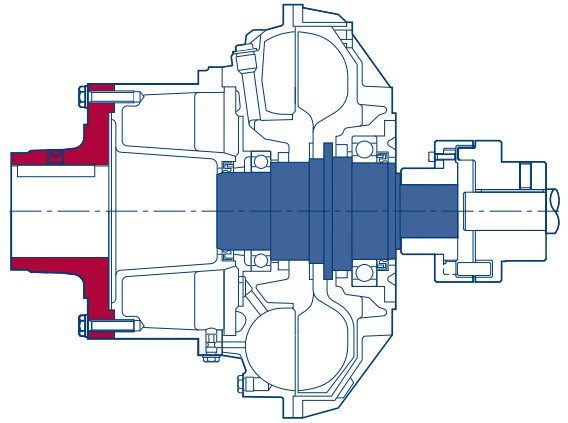

3

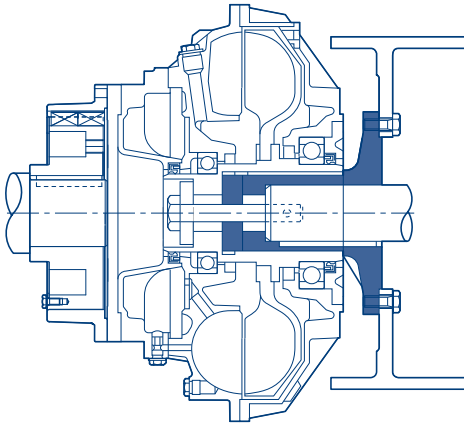

4

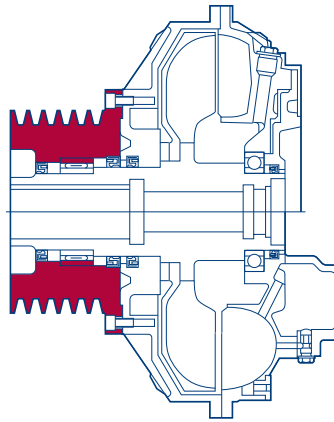

5

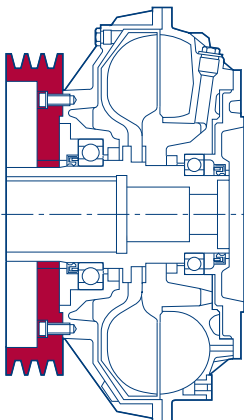

6

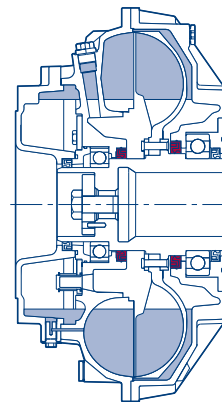

Voith Turbo GmbH & Co. KG
Startup Components
Voithstr. 1
74564 Crailsheim, Germany
Tel. +49 79 51 32-409
Fax +49 79 51 32-213
startup.components@voith.com

voith.com/fluid-couplings

VOITH
Engineered Reliability