

In-House Electrical Systems. More power without losses



The Station Supply AC System from Voith Hydro makes hydropower stations more energy efficient, because it reduces energy consumption of auxiliary transformers by up to 35 percent.

In order to generate electricity from the power of water, hydropower stations utilize a proportion of the produced electric energy for their own requirements. This energy is needed for running the in-house power station systems. The distribution of energy to the consumers within the power plant is carried out by auxiliary power supply switchgear systems. They supply pumps, fans, control technology, lighting systems and many other facilities with sufficient electricity. The auxiliary transformers ensure that the correct voltage is available.

HyEco

SustainableTechnology
in Hydro Power

Energy

Water

Environment

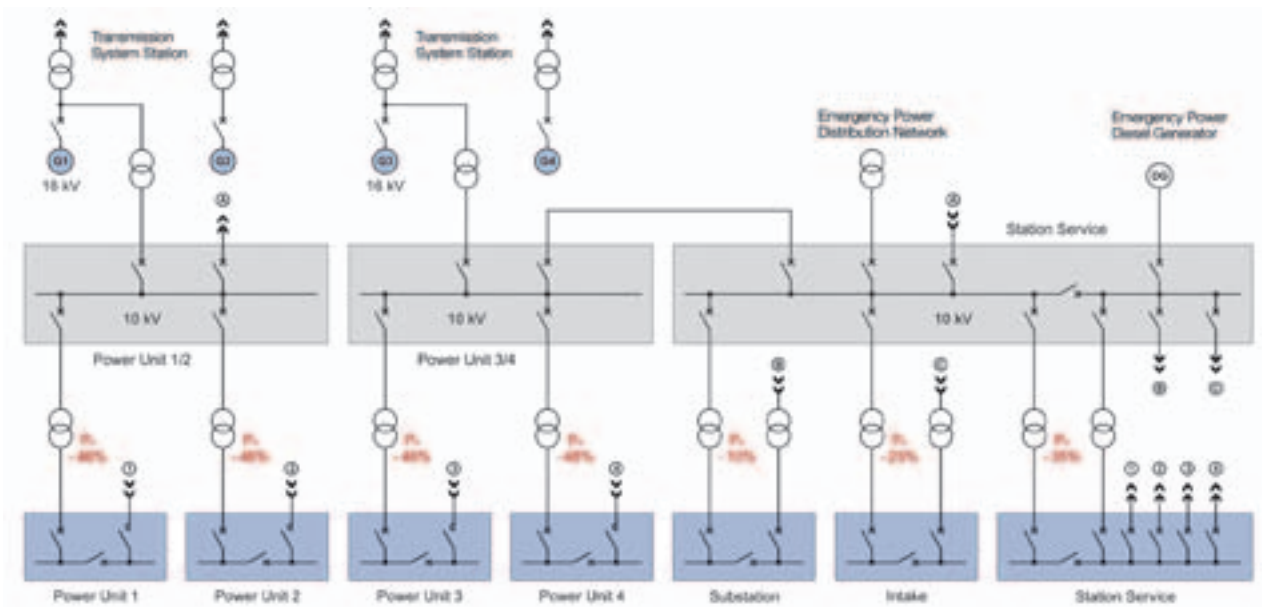

But this conversion of alternating voltage results in energy losses. The Station Supply AC System minimizes these losses and thus allows hydropower stations to operate with maximum economy.

Lower energy losses

The engineers of Voith Hydro design the transformers of the Station Supply AC Systems in such a way that their energy losses are kept at a minimum. Our experts analyze no-load and load losses. This is important, because no-load losses occur throughout the entire operating cycle of the transformers, irrespective of actual loads. In contrast, load losses depend on the power uptake of the transformers.

Each transformer within the plant has a different medial electric load during operation. Once this phenomenon is being observed, the auxiliary transformers can be optimized for specific load profiles. In contrast to conventional in-house electrical systems Voith Hydro selects the most efficient transformer for each individual load situation.

Saving up to 35 percent energy

Compared to conventional transformers, the average energy savings of all loss-optimized transformers of a Station Supply AC System can reach up to 35 percent. The saved energy is available as additional generation capacity.

Voith Hydro Holding GmbH & Co. KG
 Alexanderstr. 11
 89522 Heidenheim/Germany
 Phone +49 7321 37 0
 Fax +49 7321 37 7828
 info.voithhydro@voith.com
 www.voith.com

A Voith and Siemens Company

VOITH
 Engineered Reliability