

## Voith Schneider Propeller Types and Dimensions



Choosing the correct Voith Schneider Propeller is not only a question of hydrodynamic criteria. In each individual case, the mechanical loads on major systems components, such as blades and gear units, as well as

kinematics due to the required propeller thrust and the torque to be transmitted, have to be determined and checked. For this reason, we reserve the right to specify which propeller type should be used.

# Propeller Types and Main Dimensions

**VOITH**

VSP	
32R5 / 265-2	
Prop.no.	4068
Year built	2011

## Type R5 EC / ... -1

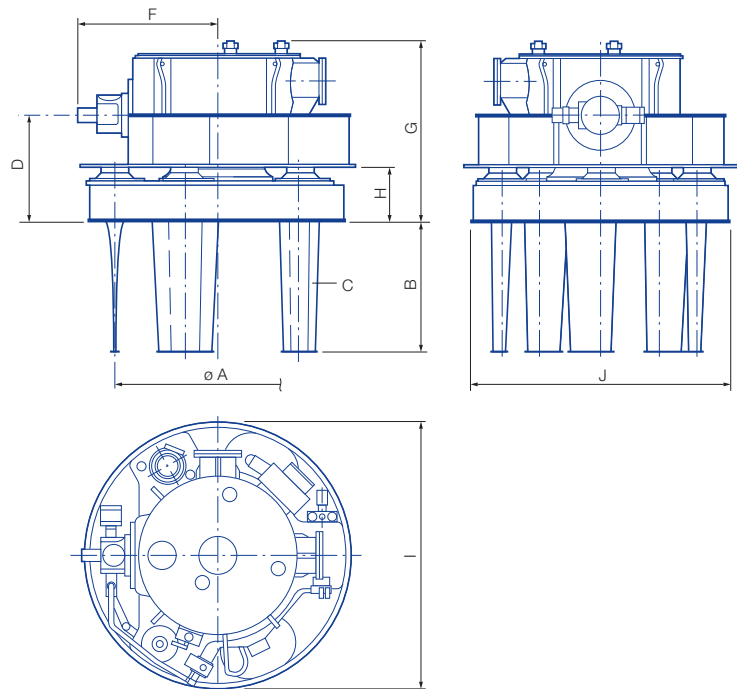
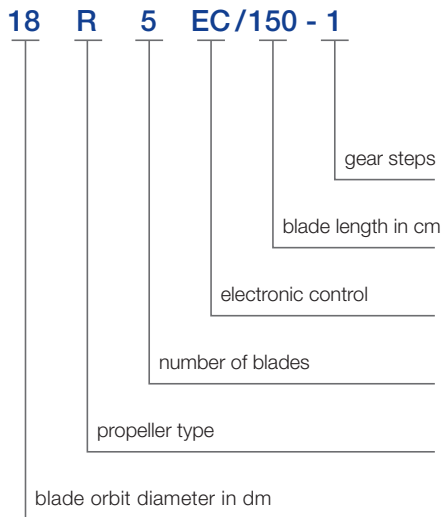

## Type R5 / ...-2

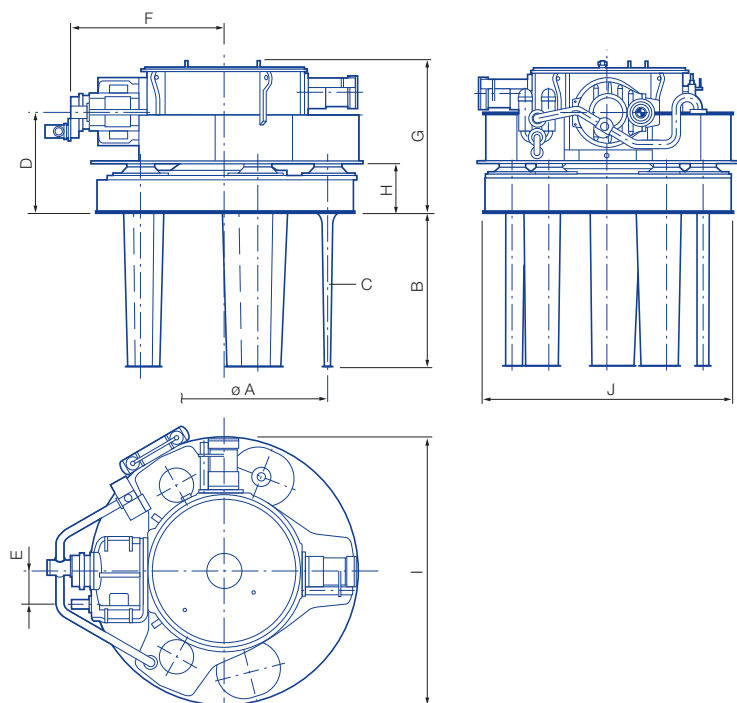
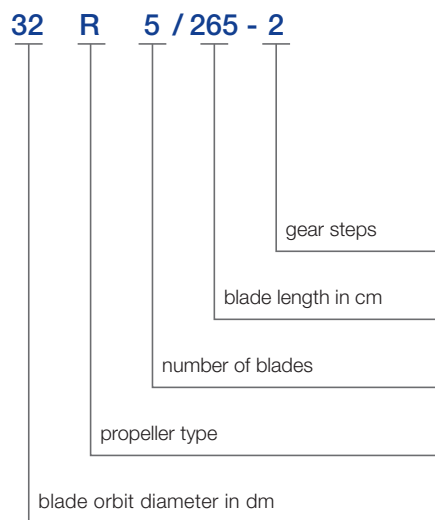

Our current production program contains different types:

Type R4 EC, R5, R5 EC(R+S), R6 EC(R)

The table features the most important dimensions, weights and moments of inertia referring to the vertical axis of rotation and the oil filling of the propellers in our current production program.

For a preliminary size determination in the initial project stage, a propeller selection according to the max. propeller input power as per the table above is possible. This table also states the permissible input speed ranges.

Propeller type/size	A	B	C	D	E	F	G	H	I	J	Weight without oil	Oil filling	Moment of inertia of rotor including additional water*	Max. propeller input power*	Propeller input speed*
	mm	mm	no.	mm	mm	mm	mm	mm	mm	mm	abt. kg	abt. l	kgm <sup>2</sup>	kW**	abt. rpm
10EG/65	1000	650	4	395	0	668	969	242	1390	1274	1960	140	160	180	900
12R4 EC/90-1	1200	912	4	550	0	1020	1185	310	1660	1532	3800	380	460	260	1000
16R5 EC/120-1	1600	1213	5	815	0	1100	1372	410	2145	2021	6700	680	2000	540	670
18R5 EC/150-1	1800	1512	5	950	0	1280	1480	450	2405	2264	9500	1000	3080	780	570
21R5/150-2	2100	1516	5	1100	360	1667	1755	500	2815	2640	16000	1600	6600	950/1000	700-1700
26R5/195-2 26R5/195-2 AE45	2600	1965	5	1340	400 450	1970 2045	1980	660	3435	3240	27500 28500	2700	20800	1350/1500	720-1200 1200-1800
28R5/210-2 28R5/210-2 AE50	2800	2115	5	1370	450 500	2135 2252	2075	670	3710	3480	33000 34500	3200	29500	1700/1900	720-1200 1200-1600
28R5/234-2	2800	2355	5	1455	450	2215	2168	730	3790	3560	36000	3700	29800	1850/2000	720-1200
28R5 ECS/234-2	2800	2355	5	1455	500	2332	2400	730	3790	3560	38500	3700	29800	1850/2000	720-1600
30R5/265-2	3000	2666	5	1580	500	2330	2380	750	4000	3780	47000	4000	44000	2250/2450	720-1200
32R5/265-2	3200	2666	5	1580	560	2475	2373	750	4250	4000	54000	4600	55000	2500/2600	720-1200
32R5 ECS/265-2	3200	2666	5	1580	560	2475	2373	750	4250	4000	54000	4600	55000	2500/2600	720-1200
32R5 ECS/300-2	3200	3016	5	1580	560	2475	2563	750	4250	4000	54000	4600	55000	2500/2600	720-1200
36R6/265-2	3600	2672	6	1900	630	2730	2820	900	4770	4490	76000	7500	104000	3050/3400	720-1050
36R6 ECR/285-2	3600	2872	6	1990	710	2840	2965	950	4765	4490	88000	7500	114000	3800/3900	700-1200
36R6 ECR/300-2	3600	3022	6	1990	710	2840	2965	950	4765	4490	86000	7500	114000	3800/3900	700-1200

- A = blade orbit diameter
- B = blade length (standard)
- C = number of blades
- D = height (input shaft)
- E = pinion offset
- F = length (input shaft)
- G = total height (propeller)
- H = well height
- I = casing outside diameter
- J = rotor casing outside diameter

\* The exact limit values must be established in consultation with us for the individual case of application.

\*\* 1st value full continuous load rating 2nd value intermittent load rating (e.g. VWT)

## Propeller Well

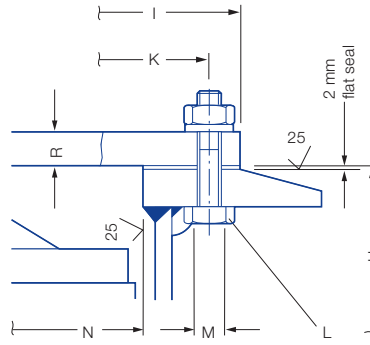
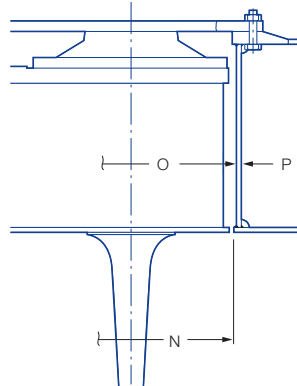
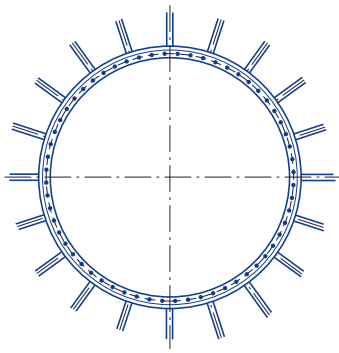

- K = bolthole circle diameter
- L = number of bolts
- M = bolthole diameter
- N = well diameter
- O = well shell diameter
- P = well shell thickness
- R = casing flange thickness

The foundation for the Voith Schneider Propeller, the so-called propeller well, consists of a cylindrical shell with a flange. The propeller well must form an integral part of the bottom structure of the vessel so that, in addition to the propeller weight, the forces and moments resulting from the propeller thrust can also be transmitted without stress concentrations in the

ship's hull. It has to be taken into account that the propeller thrust can vary by a full 360°, i.e. over the entire horizontal plane.

The structural design of the well is shown in the figures above. The dimensions, as well as the permissible tolerances for the individual propeller sizes, are included in the table on the right.

Propeller type/size	K mm	L number	M mm	N mm	O mm	P mm	R mm
10EG/65	1350	27	16	1282+3	1296	8	18
12R4 EC/90-1	1620	30	18	1540+4	1555	10	12
16R5 EC/120-1	2110	36+9	18	2032+5	2048	10	21
18R5 EC/150-1	2360	42+15	22	2275+5	2291	12	24
21R5/150-2	2760	48	26	2655+5	2675	12	28
26R5/195-2 26R5/195-2 AE45	3380	54+15	27	3260+5	3280	14	30
28R5/210-2 28R5/210-2 AE50	3640	60	27	3500+5	3530	14	35
28R5/234-2 28R5 ECS/234-2	3720	60+15	27	3580+5	3610	14	35
30R5/265-2	3930	60+21	27	3800+5	3828	16	40
32R5/265-2 32R5 ECS/265-2 32R5 ECS/300-2	4150	66+21	33	4020+5	4050	16	40
36R6/265-2 36R6 ECR/285-2 32R6 ECR/300-2	4680	72+21	39	4515+5	4550	18	50

Voith Turbo Schneider Propulsion  
 GmbH & Co. KG  
 P.O. Box 2011  
 89510 Heidenheim, Germany  
 Tel. +49 7321 37-4099  
 Fax +49 7321 37-7580  
 vspmarine@voith.com  
 www.voithturbo.com/marine

**VOITH**  
 Engineered Reliability